

GPIB BUS INTERFACES

4807

GPIB DATA ACQUISITION AND CONTROL BOARD

DESCRIPTION

The Model 4807 GPIB Data Acquisition and Control Board provides analog and digital signals for controlling virtually any kind of a device and the capability to read back analog voltages, digital signals and temperatures. The 4807 is an IEEE-488.2 compatible device and has a SCPI command parser that accepts SCPI and short form commands for ease of programming. Applications include device control, GPIB interfacing and data logging.

The 4807 is fabricated on a small 4.5 in x 5.5 in board that easily mounts on any panel or other surface in the host chassis. Analog, digital and thermocouple connections are made via a 62-pin metal-shell connector on the 4807. GPIB signals and address switch inputs are on a 26-pin header. The header mates with ICS's GPIB Connector/Switch assemblies which mount a GPIB Connector and an Address switch on the rear panel of the host chassis. The 4807 is powered by +5 volt power supply.

All of the I/O configuration settings can be changed with SCPI commands and are saved in the 4807's internal flash memory.

Temperature Measurements

The 4807 has four thermocouple inputs for reading temperatures in the host chassis. The 4807's on card compensation circuit accepts J type thermocouples and provides calibrated readings from -100 to + 400 °C with a resolution of 0.1 °C. Temperature readings are digitally filtered to reduce 60 Hz noise.

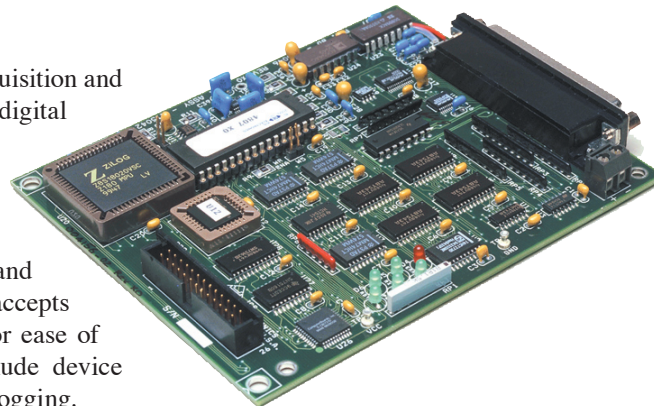

4807 Data Acquisition and Control Board

Analog Inputs

The 4807 has six single ended analog inputs with programmable unipolar and bipolar input ranges. The ranges are 0 to + 5, 0 to +10, -5 to +5 and -10 to +10 Vdc. Resolution is 1 part in 12 bits. All analog inputs are continually read and digitally filtered to reduce measurement errors and signal noise. Each channel can be individually scaled so its reading matches the measured parameter.

Analog Outputs

The 4807 has four analog outputs which provide 0 to + 5 Vdc signals. Resolution is 1 part in 10 bits. Outputs can be scaled and offset to match the controlled parameter.

Digital I/O

The 4807 has 32 digital I/O lines that can be configured as inputs or outputs in 8 bit byte increments. When used as outputs the lines are latched and can sink 48 mA or source 24 mA. As inputs the lines have pullup resistors so they can sense TTL, CMOS or contact closures.

- Combines Analog I/O, Digital I/O, Relay drivers and Temperature readings on one small board. *Versatile GPIB board controls almost any device.*
- 32-line Digital Interface configurable as gated inputs or latched outputs. *User configurable to match the application.*
- Six Analog Inputs with programmable ranges *Measures up to ±10 Vdc signals*
- Four 0 to 5 Vdc Analog Outputs. *Controls analog devices*
- High current Relay Drivers sink 300 mA. *Drive external relays or use as a digital control line.*
- Setup and IDN message saved in Flash memory. *Customize the board as part of your product.*
- Support includes a menu driven configuration program, Visual Basic and LabView programs. *Easy to use, easy to program.*
- Companion Terminal Board simplifies test connections. *Saves connection time.*

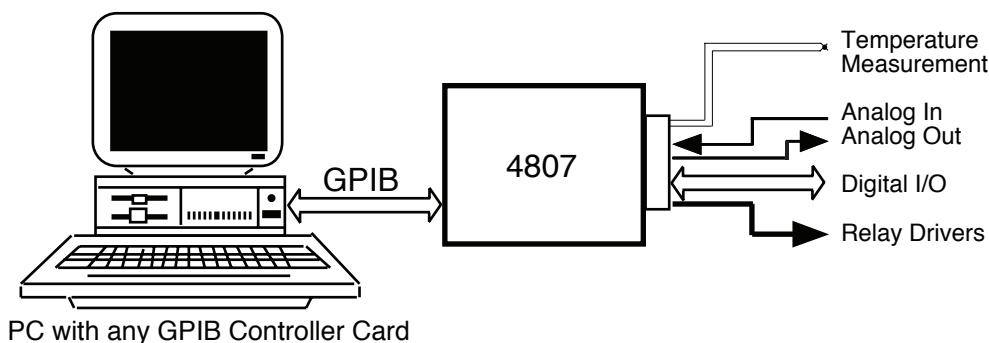

Figure 1 A Typical 4807 Application



7034 Commerce Circle
Pleasanton, CA 94588
Phone: 925.416.1000
Fax: 925.416.0105
Web: www.icselect.com

4807: DESCRIPTION

Relay Drivers

The 4807 has 6 relay driver outputs that can sink up to 300 mA. The relay driver outputs can be used to operate external relays, drive other heavy loads or function as additional digital output signals.

Signal Connections

The analog, digital and thermocouple signals are on a 62-pin, metal-shell connector with mechanical locking studs for trouble free connections in vibration prone installations. The 4807's rugged construction makes it suitable for ground, portable or airborne applications. An optional Terminal Board Assembly plugs into the 62-pin connector and provides convenient screw terminals for connecting signals to the 4807.

4807 Configuration Features

The user can set the 4807's IDN message to personalize the 4807 as part of the end product. The IDN message, the I/O signal configuration and other settings are saved in the 4807's nonvolatile Flash memory. The saved settings are recalled as the default settings at power turn-on. A lock command blocks the configuration settings from being accidentally changed by the end user while letting him change the GPIB address. Removing the write jumper inhibits all writes to the 4807's Flash memory and blocks any changes to the board's configuration.

SCPI Command Parser

The Model 4807 includes a SCPI command parser, an IEEE-488.2 STD status structure and also responds to all of the required 488.2 common commands. The 4807's parser lets the user program the 4807 with the SCPI commands (Standard Commands for Programmable Instruments) shown in Table 1 or use short form commands.

Table 1 4807 SCPI COMMAND TREE

SYSTEM	Configuration
:COMM	
:GPIB	
:ADDRESS	<numeric>
:EXT	boolean
:ERROR?	
:VERSION?	(1996.0)
STATUS	
:OPERATION	
:CONDITION?	
:ENABLE	<numeric>
:QUESTIONABLE	Digital Inputs
:CONDITION?	
:ENABLE	<numeric>
:PTRANSISTION	<numeric>
:NTRANSISTION	<numeric>
CONFIGURE	Data Strings
[:DIGITAL]	
:INPUT	<channel list>
:POLARITY	boolean
:OUTPUT	<channel list>
:POLARITY	boolean
FORMAT	Data Format
[:DATA]	
:TALK	
:LISTEN	
SOURCE	Analog Outputs
:VOLTAGE	
[:LEVEL]	
[:IMMEDIATE]	
[:AMPLITUDE]	<numeric>
:TRIGGERED	
[:AMPLITUDE]	<numeric>
:LIMIT	
[:AMPLITUDE]	<numeric>
:OFFSET	
[:AMPLITUDE]	<numeric>
:RANGE	<numeric>
:SLOPE	
[:AMPLITUDE]	<numeric>
[:DIGITAL] Port Outputs	
:DATA	
[:VALUE]	0-255
:PORTn	0-255
:POLARITY	0-255
ROUTE	Relay Driver Outputs
:CLOSE	<channel list>
:STATE?	
:OPEN	<channel list>
:ALL	

Table 1 4807 SCPI COMMAND TREE

Cont'd

MEASURE	Analog Inputs
:VOLTAGE?	
[:DC]	<channel list>
:RANGE	<numeric>
:POLARITY	<numeric>
:AVERAGE	<numeric>
:TEMPERATURE	<channel list>
SENSE	Digital inputs
[:DIGITAL]	
:DATA	
[:VALUE?]	
:PORT	<channel list>
:PORTn?	
:POLARITY	<numeric>
CALIBRATE	Calibrate
:MEASURE	
:GAIN	<numeric>
:NGAIN	<numeric>
:OFFSET	<numeric>
:IDN	<string>
:FAULT	0 1

Table 1 shows the 4807's SCPI command tree. The SYSTEM command group sets the 4807's GPIB address and enables the external address switch.

STATUS group can sense digital input changes through the Questionable Status Register. CONFIGURE commands group multiple bytes together as inputs or outputs so digital data can be passed as strings. Unconfigured bytes can be directly read or written to with the byte oriented commands.

FORMAT commands set the data format for transferring data as strings.

SOURCE command group controls the analog and digital output functions. The analog outputs can be set from 0 to 5 Vdc. The digital outputs can be set by direct writes to a specific port or by a data string written to the configured output ports.

ROUTE commands set and clear the relay driver outputs.

MEASURE command group sets the analog input ranges, filter constants, reads the analog inputs and temperature input values.

SENSE group controls the digital input functions. Digital inputs can be read directly from a specific port or as a data string from the configured input ports.

The CALIBRATE group saves the calibration values in Flash and has a default command to restore the factory settings.

4807: DESCRIPTION

GPIB Interface

The 4807 has a 26-pin header with GPIB and Address Switch input signals. When the external address functions are enabled, the 4807 reads the address switch inputs at power turn-on time. If the external address switch is not enabled, the 4807 uses the GPIB address saved in its Flash memory. The GPIB connector mates with ICS's GPIB Connector/Address Switch Board Assemblies. The Connector/Address Switch Assemblies are small business card size PC assemblies that mount a GPIB connector and a 8-bit Address rocker switch to the rear panel of the host chassis. They have a flat ribbon cable which plugs into the header. The assemblies are available in two layout styles and can be ordered with cable lengths up to 90 cm. Refer to the GPIB Connector/Address Switch data sheet for assembly styles, mounting dimensions and cable length ordering information.

Sample Application

Figure 2 on the right shows a sample application for the 4807 that shows off its interface capabilities. Byte 1 is read with a port command to sense contact closures. Bytes 2 and 3 are configured as inputs and read with a string command. Byte 4 is used to control a LED display. The Relay Drivers enable the display and operate a relay to power a motor. The D/A outputs control the motor. The A/D inputs sense the feedback potentiometer and supply voltages. The Thermocouple inputs read the motor's temperature.

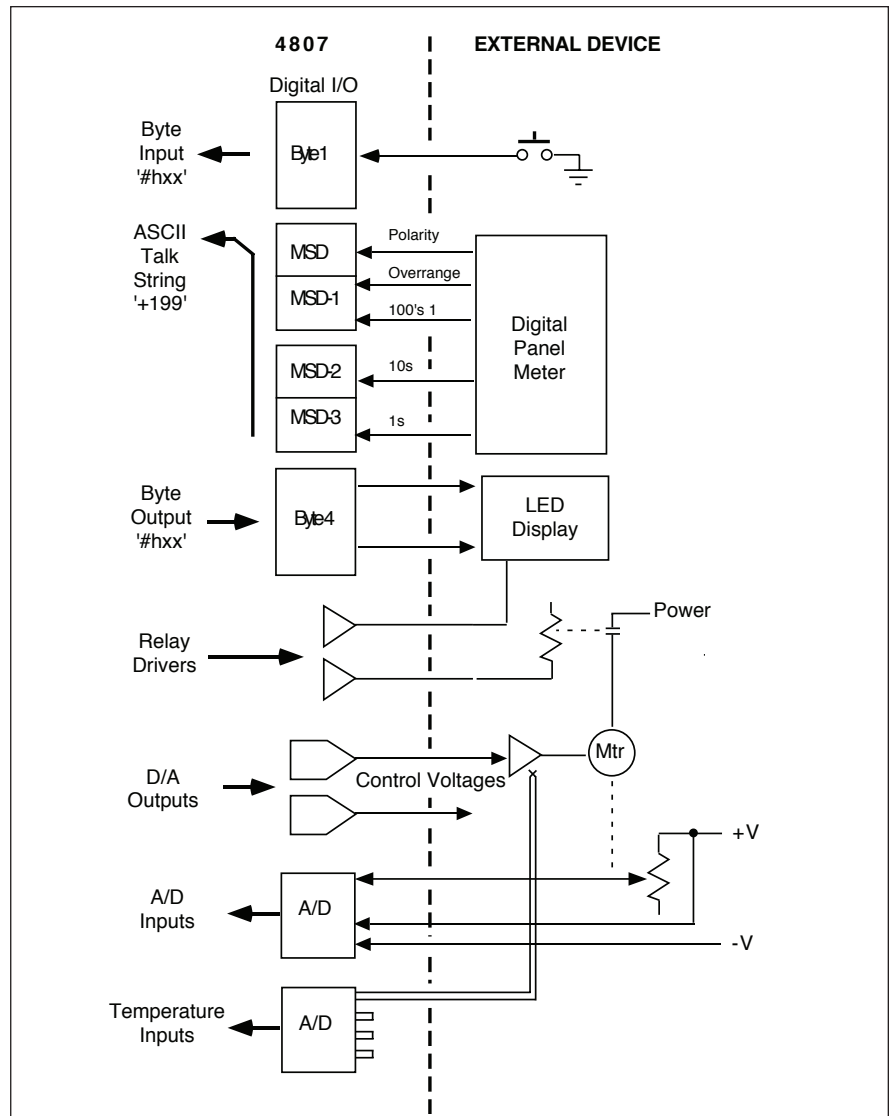
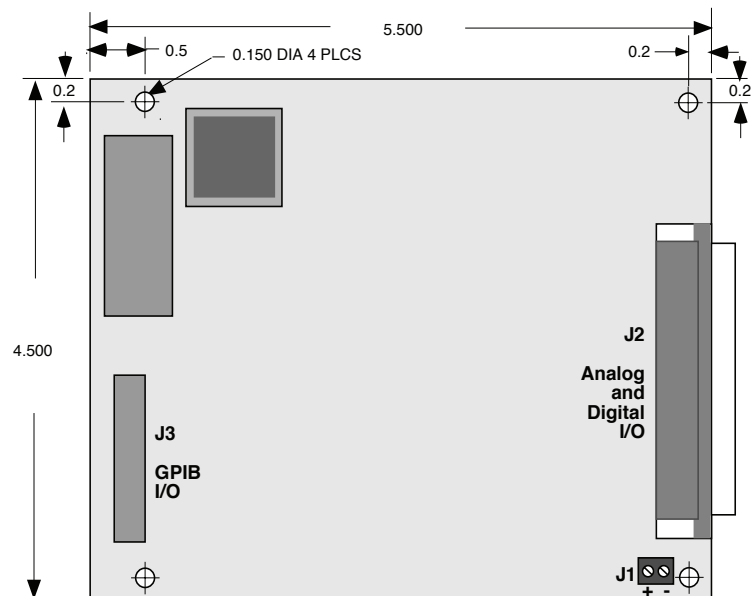

Figure 2 4807 Sample Application

Physical Description

The 4807 is packaged on a small 4.5 inch x 5.5 inch PC board. Maximum component height is 0.5 inches. The 4807 has four mounting holes for mounting it against a panel or on a larger PC board. The GPIB signals and address switch inputs are on header J3 as described above. All of the analog, digital, relay and thermocouple signals connections are on J2. J2 is a hi-density, right-angle, 62-pin connector with a metal shell and lock studs. Mating connectors are available with solder eyelets, poke-in pins or with right-angle solder tails. 5 volt regulated power is connected to the 4807 via the screw terminal block, J1.



Note - All dimensions are in inches

Figure 3 4807 Board Outline Dimensions

4807: SPECIFICATIONS

IEEE 488 Bus Interface

The 4807's 488 Bus interface meets IEEE STD 488.1-1987 and has the following capabilities:

SH1, AH1, T6, L4, SR1, PP0, DC1, RL0, DT1, C0 and E2 drivers.

Address Capability

Primary address range: 0-30.

SRQ Generation

SRQs are generated if the unit is not a talker, if SRQs are enabled and if an Enabled Event Status Register bit change occurs.

488.2 Common Commands

*CLS, *ESE, *ESE?, *ESR?, *IDN?, *OPC, *OPC?, *RCL, *RST, *SAV, *SRE, *SRE?, *STB, TST? and *WAI

SCPI Commands

Used to set and query all programmable functions. The 4807 conforms to SCPI 1994.0 Specification.

Digital I/O

32 lines configurable as input or outputs in 8-bit byte increments.

Input High => +2.4 V
Logic Low =<0.5 V
Levels 33 Kohm pullup to +5 Vdc for normally open contacts.

Output High =>3 V, 3 mA source
Logic High =>2 V, 24 mA source
Levels Low = 0.0 to +0.8 Vdc, 48 mA sink

Analog Inputs

Six single ended inputs with programmable ranges.

Ranges	± 10 , ± 5 , 0 to +5, 0 to + 10Vdc
Max Input	16 Vdc
Resolution	1 part in 12 bits
Accuracy	4 bits
Offset	5 bits (Zero and end points)
Scaling	Offset and gain
Scan Rate	50 samples/sec
Averaging	1 to 100 samples
Response	8.5 ms after terminator
Signal Z	< 4 ohm for bipolar < 15K for unipolar

Analog Outputs

Four outputs with common ground.

Vout	0 to 4.99 Vdc (Limited to Vcc-30 mV)
Resolution	1 part in 10 bits (4.88 mV)
Accuracy	2 bits (Non-linearity)
Offset	4 bits (Zero and end point)
Load	5 kohms maximum
Step	2.5 volts/10 μ sec
Scaling	Offset and Gain
Update	8 ms after terminator

Driver Outputs

Six open collector relay drivers

Imax	300 mA
Vmax	48 Vdc
Response	2 ms after terminator

Temperature Measurements

Four type J thermocouple inputs

Range:	-100 to + 400 °C
Resolution	0.1 °C
Accuracy	± 2 °C exclusive of thermocouple error
Filter	1 to 100 samples

Diagnostic Indicators

Six on board LEDs:

PWR, RDY, MTA, MLA, SRQ and ERR.

Physical

Size, L x W x H

139.7 x 114.3 x 12.7 mm
(5.5 x 4.5 x 0.5 inches)

Connectors and Headers

GPIB: 26-pin (2 row x 13 pin) header
 Data: 62-pin DC shell female connector
 Power: 2 screw terminals

Temperature

Operation -10 °C to +70 °C
 Storage -20 °C to +85 °C

Humidity

0-90% RH, no condensation

Power

+5 \pm 0.2 Vdc@ 400 mA (typ)

Included Accessories

Instruction Manual

Configuration Disk with configuration programs and sample Visual Basic program.

62-pin mating connector and hood

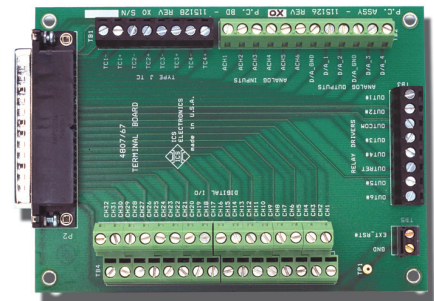

48x7/23x7 Terminal Board Assembly

ORDERING INFORMATION

	Part Number
GPIB Data Acquisition and Control Board (Includes Instruction Manual and Configuration CD-ROM)	4807
GPIB Data Acquisition and Control Board without Thermocouple Inputs (Includes Manual and CD-ROM)	4807-TC
GPIB Data Acquisition and Control Board, board only	115042
GPIB Data Acquisition and Control Board without Thermocouple Inputs, board only	115041
48x7/23x7 Terminal Board Assembly	115124
GPIB Connector/Address Switch Assemblies	see separate data sheet