

4894A-7/4804A-7 Addendum

A.1 INTRODUCTION

This Addendum provides additional information about the 4804A-7 and the 4894A-7 when used as a GPIB to ANSI X3.28 Serial Interface and the operation of special programs F30145 and F30146. This Addendum describes the F30145 program changes for the 4804A-7. All comments apply to the 4894A-7 with program F30146 unless otherwise noted.

Refer to the 4894A/4804A Instruction Manual for GPIB or serial connections, for 488.2 commands and for general information about either unit.

A.2 GENERAL

The F30145 Program enables the 4804A to operate as an IEEE-488.2 Interface for ANSI X3.28 devices and to perform the GPIB to ANSI X3.28 protocol conversion. The ANSI X3.28 protocol is typically used by temperature controllers with serial interfaces to control the operation of temperature chambers and similar equipment. The F30146 program performs the same function in the 4894A.

When the F30145 program is installed, the 4804A responds to the *IDN? query with the Model number "4804A-7 F30145". The 4894A with program F30146 responds with the Model number "4894A-7 F30146".

The F30145 program does **not** use the escape sequence described in the 4894A/4804A Manual to switch to the Command sub-mode or "SYST:OPER DATA" to switch to the Data sub-mode. There is no sub-mode switching as the command parser is active at all times with programs F30145 and F30146.

P/N 120168 Rev 3-14-07

The 4804A-7 with program F30145 responds to three types of commands: IEEE-488.2 Common Commands, SCPI commands and simplified ANSI commands that are passed through to the Temperature controller. The IEEE-488.2 Common Commands are listed in Table 3-1 in the 4894A Manual. The F30145/F30146 SCPI Commands are listed in Table 2 of this Addendum. The ANSI Commands are listed in your temperature Controller Manual.

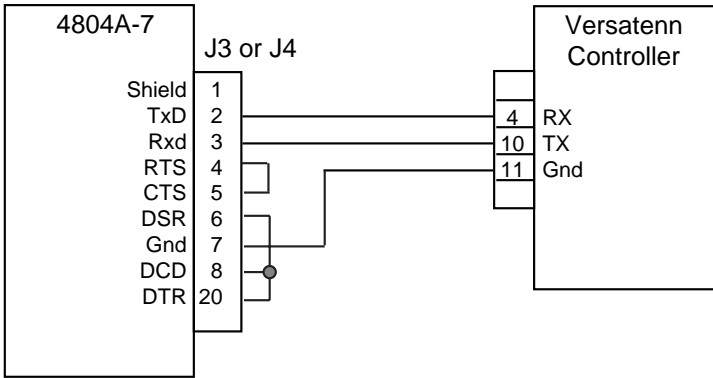

Figure 1 RS-232 Connections to a Versatenn

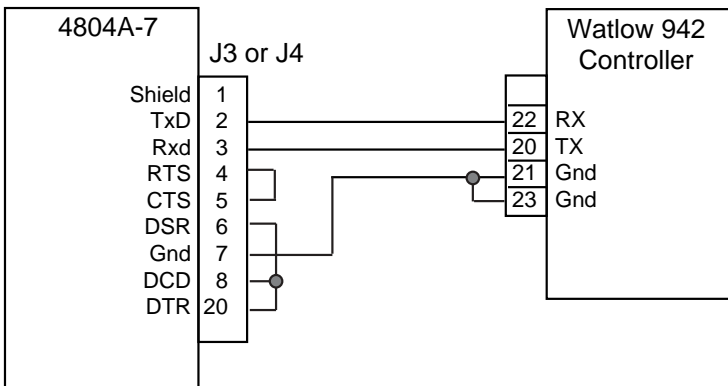

Figure 2 RS-232 Connections to a Watlow 942

A

A.3 TEMPERATURE CONTROLLER CONNECTIONS

The following diagrams show the 4804A-7's RS-232 connections to two of the more popular temperature controllers that use the ANSI X3.28 protocol. Figure 1 shows the connections to a Lunaire (Tenny) Versatenn. Figure 2 shows the connections to a Watlow 942 Temperature Controller. Refer to Section 2 of the 4894A/4804A Instruction Manual for more information about the 4804A and 4894A serial interfaces.

The RS-232 connections shown in Figures 1 and 2 are recommended for both temperature controllers as their RS-232 interfaces can operate reliably at a 9600 baud rate. The RS-422 connection should be limited to 1200 baud..

A.4 ANSI X3.28 PROTOCOL

The 4804A-7 responds to all ANSI messages from the GPIB bus with a value or status response. The user **must** read the 4804A-7 after each message or else a Query error will result when the 4804A-7 is next addressed as a listener. If the 4804A did not receive a response from the ANSI device or if the response was not the expected response, the 4804A-7 will respond with an error message when addressed to talk. The ANSI Error messages are listed in Table 1.

TABLE 1 ANSI Error Messages

Message	Error
Error-TMO	Message not received before the internal timeout period ended.
Error-No STX	Expected STX character not received at start of message.
Error-No ETX	Expected ETX character not received at end of message.
Error-undefined resp	Response from serial device not recognized.



TABLE 2 SCPI Command Tree

Keyword	Parameter Form	Notes
SYSTem		
:COMMunicate		
:SERial		
[:RECeive]		
:BAUD	<numeric value> [1200]	
:PARity	EVEN ODD NONE [ODD]	
:BITS	<numeric value> [7]	
:SBITs	<numeric value> [1]	
:RS485	0 1 or OFF ON [0]	
:TIMEout	0 65535 [250]	
:UPdate		
:GPIB		
:ADDRess	<numeric value> [4]	
:EXTernal	0 1 or OFF ON [0]	
:ERRor?	(0, "no error")	
VERSion?	(1995.0)	
CALibrate		
:IDN	string	
:DATE	mm/dd/yy or mm/dd/yyyy	
:DEFault		
:LOCK	0 1 or OFF ON [0]	

Note: Values in brackets [] are factory default settings

A.5 LED CHANGES

The function of two LEDs changes when Program F30145 or F30146 is installed.

BUSY becomes SRQ and is on when SRQ is asserted

FULL becomes ERR and is on whenever the following bits in the ESR Register are set.

Bit 2 - Query Error

Bit 4 - Execution Error

Bit 5 - Command Error

Querying the ESR Register with *ESR? or sending *CLS will clear the bits.

A.6 OPERATION

The following paragraphs describe how to setup and use the 4804A-7 to initialize the ANSI device (temperature controller) and how to send messages and queries to the ANSI device. This Addendum is not meant as a manual on how to use your ANSI device. After you have finished these steps, consult the ANSI device (temperature controller) manual or the equipment supplier for the proper way to use the chamber and for its command syntax.

A.6.1 4804A-7 Configuration Commands

The 4804A-7 responds the SCPI commands shown in Table 2 to change its GPIB and serial settings. SCPI commands are a branch type structure that starts at the root word and branches out to the command word.

i.e. **SYST:COMM:SER:BAUD 9600** or
SYST:COMM:GPIB:ADDR 7

A parameter like 9600 is separated by a space from the last command word. To query a setting, add a question mark to the end of the command without the space.

i.e. **SYST:COMM:SER:BAUD?** or
SYST:COMM:GPIB:ADDR?

When changing the 4804A-7's settings, any new values must be saved with the ***SAV 0** command before restarting or powering the unit off, else they will be lost. Note that serial changes only take place if the unit is powered off and back on or when the unit is given the UPdate command. GPIB Address changes take place immediately and you must change the GPIBkybd to the new address to send the ***SAV 0** command. The CAL:DEF command can be used to return all settings to the factory default values. Refer to the 4894A/4804A Instruction Manual for information about the 488.2 Commands and the 4804A-7's IEEE 488.2 Status Reporting Structure.

A.6.2 Verifying GPIB Communication

Use an interactive GPIB control program like ICS's GPIBkybd program to communicate with the 4804A-7. ICS's GPIBkybd program works with all National Instrument, most ICS and all Measurement Computing GPIB

A

Controllers. You can download the latest GPIBkybd program from ICS's website at <http://www.icselect.com>. From the Support menu, select the GPIB Drivers page and scroll down to the GPIBkybd program.

Send the 4804A-7 the *IDN? query. It will respond with an IDN message. ICS's factory message is 'ICS Electronics, 4804A-7 F30145, S/N 411123, rev 04-11-11'. The unit may also respond with an IDN message that was programmed into it by the Temperature Chamber manufacturer which is also okay. Just be sure that the IDN message is a good readable message without odd graphic characters.

A.6.3 4804A-7 and ANSI Device Setup

The 4804A-7 (or 4894A-7) and the ANSI Device must be set to the same serial settings for successful serial communication. Use the SCPI commands in Table 2 to query or change the 4804A-7's serial setup. ICS's recommended values for RS-232 connections is 9600 baud, 8 data bits, no parity and 1 stop bit. 19,200 baud also works with RS-232 connections. For RS-422 connections, reduce the baud rate to 1200 baud. Set the Serial Timeout value to 300 milliseconds. The RS485 parameter can be 0 or 1.

ANSI devices like temperature controllers have their serial settings set either on the front panel or by rocker switches on the rear of the unit. Refer to the ANSI device's manual for directions on verifying or changing its serial settings. Also verify its ANSI Device ID number. This is typically 0 or 1.

A.6.4 ANSI Device Initialization

The ANSI device(s) should be initialized at power turn-on or when a communication error occurs by sending the 4804A-7 the GPIB Selected Device Clear Command. The 4804A-7 then sends the serial <DLE><EOT> characters to the ANSI device. <> defines a non-printable ASCII character. There is no GPIB response to the Selected Device Clear command.

A Selected Device Clear is a Device Clear command that is sent to a specific GPIB device. **Device Clear is a GPIB command and is not sent as an ASCII character string.**



On the GPIBkybd, a Selected Device Clear is sent by pressing the Device Clear button in the 488.1 Command box. If you want to send a Selected Device Clear from your program, use the DevClear command. DevClear is a National Instruments, ICS and Measurement Computing 488.2 command. If you are using another GPIB Controller, check its User Manual for the equivalent command.

A.6.5 Establishing the ANSI Communication Link

Next, a communication link must be established to the ANSI device before other commands or queries can be sent to it. The communications link is established by sending the ANSI Device ID number to the 4804A-7. See paragraph A.6.2. The 4804A-7 sends the number plus the <ENQ> character to the ANSI Device to open the communication link. If the link was successfully opened, the 4804A-7 responds with the number plus 'ACK' . If the link was not established, the reply is a the number plus 'NAK' or an error message. If multiple ANSI devices are on the same serial link, a communication link will have to be opened to a specific device before commands can be set to it or when switching devices. A GPIB example is:

GPIB Ctlr sends	0<nl>
4804A-7 responds	0ACK<nl>

<nl> is the newline message terminator and is normally a linefeed character. (It can also be EOI asserted on the last character or a combination of both.) ICS's GPIBkybd program automatically adds the <nl> character to any message sent out on the GPIB bus. It also strips off any received linefeeds unless the show all characters box is checked.

A.6.6 ANSI Command Example

To set a parameter in the ANSI device, send the device's command string to the 4804A-7. The 4804A-7 will reply with an "ACK if the command was accepted. If the command was not accepted, the reply will be an "NAK' or an error message. A common temperature setting command is "= SP1". "= SP1 100" sets a temperature of 100. A GPIB example is:

GPIB Ctlr sends	=<space>SP1<space>100<nl>
4804A-7 responds	ACK<nl>



A.6.7 ANSI Query Example

To query the ANSI device, send the device's query string to the 4804A-7. The 4804A-7 will reply with the value if the query was successful. If the query failed, the reply will be a NAK or an error message. Common queries are "? C1" and "? SP1". GPIB examples are:

GPIB Ctlr sends	?<space>C1<nl>
4804A-7 responds	210<cr><nl>

GPIB Ctlr sends	?<space>SP1<nl>
4804A-7 responds	100<cr><nl>

