

# RS-232/RS-485 SERIAL INTERFACES

## 2361A

### RS-232/RS-485 TO ANALOG INTERFACE

#### DESCRIPTION

The Model 2361A is a compact, RS-232/RS-485 to Analog Interface that provides signals for controlling analog devices over a serial path. The Model 2361A has four floating analog output channels, four differential analog inputs, digital output drivers and digital inputs. The analog values can be scaled to match the physical values of the input signals or of the controlled parameters. The scale factors and all other user set configuration parameters are saved in Flash memory until changed. The 2361A's serial interface provides the functionality of a GPIB interface with control from any PC's COM port or over a RS-485 network. The 2361A accepts both industry standard SCPI commands and easy-to-use short form commands. Typical 2361A applications are controlling power supplies, providing analog stimuli or measuring analog signals.

OEM board versions of the 2361A are available in a variety of configurations to match the analog control needs. The 2361A's firmware can also be customized to add new commands for specific applications.

#### Analog Outputs

The 2361A's analog outputs are individually isolated by 750 volts from digital ground. Channel 4 is referenced to the A/D converter ground. Each analog output can be individually set to a 0 to +10, a  $\pm 10$ , or to a  $\pm 5$  volt output range. Resolution is 1 part in  $2^{16}$ . The analog outputs have separate range, scale factor, offset and limit values that the user can program to match the controlled application.



2361A Serial to Analog Interface

#### Analog Inputs

The 2361A has four isolated differential analog inputs that are multiplexed into a 12 bit A/D converter, scanned 150 times a second and internally averaged. The A/D converter can be set for unipolar or bipolar inputs with programmable 10, 1 and 100 mV ranges. The A/D readings can be reported as voltages or scaled to correspond to the measured parameter, i.e. volts, amps, watts, psi, etc.

#### Digital I/O

The Model 2361A provides eight digital inputs and four relay driver output signals. The digital inputs have pullup resistors and can accept TTL / CMOS levels or contact closures. The 2361A's firmware provides for direct reading of the digital signals or for monitoring the signals for changes. Any changes in the digital inputs can be used to generate a Service Request Message. The digital outputs are darlington drivers that sink up to 200 mA and incorporate protection diodes for driving relays or other inductive devices. Each output can be individually controlled. Output #4 can also be used as a Fault Output signal to display error conditions.

- Provides four floating 16-bit analog outputs with 750 Vdc isolation. *Controls analog devices without ground loops.*
- Four differential analog inputs with programmable ranges. *Scalable inputs for reading voltage sources, current shunts, sensors etc.*
- User settable scale factors for all analog signals. *Matches 2361A commands and data to real values.*
- High current drivers can operate external relays etc. *Digital control of external devices*
- Digital inputs read or monitor external signals. *Generates Service Request Message on selected signal changes.*
- RS-485 network capability. *Supports multiple units on one RS-485 network.*
- Includes sample control, calibration and configuration programs. *Complete software package.*



2361A OEM Board

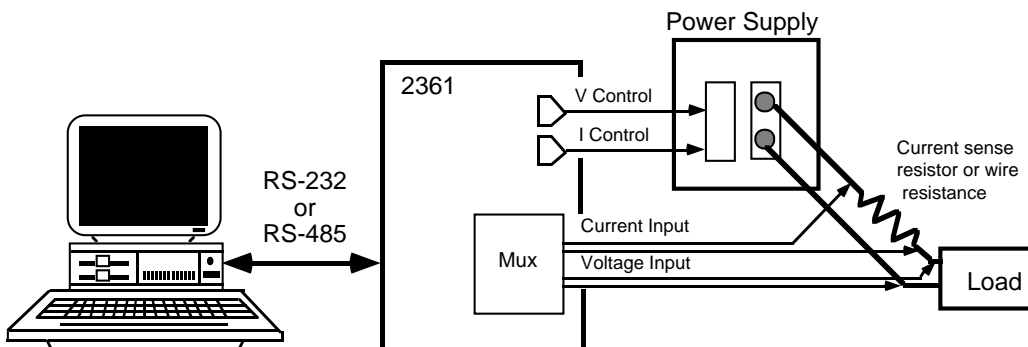

Figure 1 Using the 2361A to control a power supply and measure its outputs



7034 Commerce Circle  
Pleasanton, CA 94588  
► Phone: 925.416.1000  
Fax: 925.416.0105  
Web: www.icselect.com

## Scaling

Programmable scale factors and offsets let the user program the 2361A's output and read measured values in real world numbers. The 2361A's output voltage follows the equation

$$V_{out} = (M * V_{cmd}) + B.$$

Figure 2 shows two examples of output voltage scaling by changing the slope (M) and offset (B) values. Similarly, measured voltages may be scaled to provide actual values for divided inputs or converted to other units when measuring sensor signals. The scaling values may be saved in the 2361A's Flash memory.

## Digital Calibration

The 2361A is digitally calibrated for increased accuracy and to eliminate all internal adjustments. The analog outputs are corrected to  $< \pm 4$  bits. The analog inputs are calibrated for each range and channel. The calibration factors are saved separately in flash memory and are recalled at power turn-on. Full calibration instructions and a PC calibration program are included with each unit.

## IEEE-488.2 and SCPI Commands

The Model 2361A includes an IEEE-488.2 STD status structure and responds to all of the required 488.2 common commands. The 2361A's parser lets the user program with SCPI (Standard Commands for Programmable Instruments) commands or use ICS's short form commands listed in Table 1.

Table 2 shows the 2361A's SCPI command tree. The SYSTEM command group sets the Serial parameters and enables the Serial address function for RS-485 networks. The STATUS group can sense digital input changes through the Questionable Status Register. The INSTRUMENT command group sets the input or output channel number. The MEASURE and SOURCE command groups control the analog input and output functions. The OUTPUT group controls the four digital output lines. The CALIBRATE group saves the calibration values in Flash and has a default command to restore the factory settings.

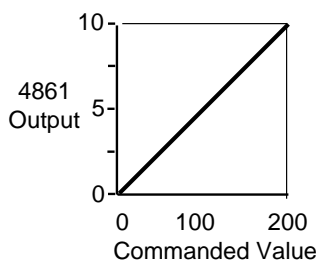

Example for a 0 to 200 volt supply with  $M = .05$ ,  $B = 0$

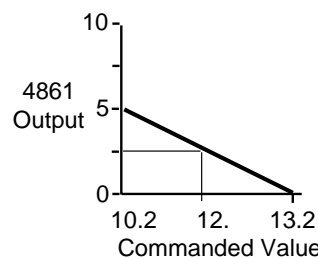

Example for a 12V  $\pm 10\%$  supply with  $M = -2.083$  and  $B = 27.5$

Figure 2 Output Voltages for different Scale Factors and Offsets

## RS-232/RS-485 Interfaces

The 2361A provides both RS-232 and RS-485 signals on its 25-pin rear panel connector. The RS-232 interface is a full-duplex, three wire interface. The 2361A's RS-485 interface is a two wire, half duplex interface for point-to-point or network connections.

## Serial Address Detection

The 2361A's serial address detection capability lets the user to control up to sixteen 2361As on a single RS-485 network. When address recognition is enabled, the 2361A looks for presence of the STX character followed by its address character before acting upon the remainder of the attached command string. The address character is saved in the 2361A's Flash memory. A separate command lets the user enable or disable the address sequence.

TABLE 1  
2361A Short Form Command Set

Command	Function
C n	Selects channel
DB n	Sets analog polarity
D nn.nnn	Sets analog output
T n	Enables Trigger n
M nn.nnn	Sets analog scale factor
B nn.nnn	Sets analog offset
L nn.nnn	Sets output limit
DD h	Sets digital outputs
DP h	Sets digital polarity
OC h	Sets digital outputs
OP h	Sets digital polarity
A? n	Read analog input n
AR n	Sets analog input range
AB n	Sets input polarity
AF n	Sets input averaging
AC nn.nnn	Sets input gain
AO nn.nnn	Sets input offset
AM	Enables auto scan
DO nn.nnn	Calibrates output offsets
DC nn.nnn	Calibrates input gain
DL nn.nnn	Calibrates input offset

TABLE 2  
2361A SCPI COMMAND TREE

SYSTEM	Serial Configuration
:COMM	
:Serial	
:BAUD	<numeric> [9600]
:BITS	7   8
:PARITY	ODD   EVEN   NONE
:SBITS	1   2
:NETwork	0   1
:ADDRess	0-15
:ERRor?	
:VERSion?	(1996.0)
:ERRor?	
:VERSion?	
STATus	
:OPERation	WTG Status
:CONDition?	
:ENABle	<numeric>
:QUESTionable	Digital Inputs
:CONDition?	
:ENABle	<numeric>
:PTRansistion	<numeric>
:NTRansistion	<numeric>
INSTRument	Channel Select
:NSElect	<numeric>
SOURce	Analog Outputs
:VOLTag	
[:LEVel]	
[:IMMEDIATE]	
[:AMPLitude]	<numeric>
:TRIGgered	
[:AMPLitude]	<numeric>
:LIMit	
[:AMPLitude]	<numeric>
:OFFset	
[:AMPLitude]	<numeric>
:RANGe	<numeric>
:SLOPe	
[:AMPLitude]	<numeric>
:DIGital	Digital Outputs
[:DATA	
[:VALue]	
:POLarity	
OUTPut	
:STATe	<bool>
:POLarity	
MEASure	Analog Inputs
:VOLTag?	
[:DC]	channel list
:RANGe	<numeric>
:POLarity	<numeric>
:AVERage	<numeric>
CALibrate	Calibrate
:SOURce	
:OFFset	<numeric>
:MEASURE	
:GAIN	<numeric>
:OFFset	<numeric>
:IDN	<string>
:FAULT	<bool>

**Physical Description**

The 2361A is packaged in ICS's compact Minibox case that is only 7.2 x 7.2 inches square and 1.5 inches high. One or two 2361As can be rack mounted in a 1 U (1.75 inches) high rack mounting kit. The 2361A's rear panel contains the analog-digital connector, the power jack and the serial connector. Analog and digital connections for are made through a 62 pin D shell connector. Mating connectors are available with solder eyelet or poke-in pins. Table 4 lists the analog and digital signal-pin assignments. Power is provided by a wall mounted adapter but the user can run the 2361A from any 12 Vdc regulated source.

**OEM Board Versions**

The 2361A is available as a board version for OEM applications. Board versions are designed to be mounted in the host's chassis and powered from the host's power supply. The boards are available with various output configurations as listed in Table 3.

**Serial Header**

On OEM boards, the 2361A's 25-pin rear panel Serial connector is replaced with a 10-pin header for remoting the serial signals to the rear panel. The 10-pin header has pins on 0.1 inch centers and mates with a variety of connectors including flat ribbon cable type connectors. The Serial header includes the 2361A's RS-232 and RS-485 signals plus a reset input signal.

**LED Header**

An 8 pin header on the OEM boards provides LED drive signals and a +5 Vdc line to extend the 2361A's LEDs to the user's front panel.

**OEM Customization**

2361A's firmware allows the user to store his IDN message, scale factors and other setup parameters in the 2361A's Flash memory. This effectively integrates the 2361A into the end product and makes the system appear as the OEM's product. A lock function hides the setup variables from the end user and prevents accidental changes to the setup.

**Starter Kit**

The OEM Starter Kit provides the OEM designer with everything a user needs to test and evaluate a 2361A OEM Board. The kit includes a 114584-14 Board, a serial cable, and 2361A development software and an instruction manual. The software package includes a keyboard command line program, a Visual Basic control program and 2361A test and calibration programs. Order the 2361A OEM Starter Kit as P/N 114679

**TABLE 3 OEM BOARD CONFIGURATIONS**

Part Number	Analog		Interfaces		Notes
	Outputs	Inputs	RS-232	RS-485	
114671-12	2	-	Yes	Yes	
114671-14	4	-	Yes	Yes	
114671-22	2	4	Yes	Yes	
114671-24	4	4	Yes	Yes	

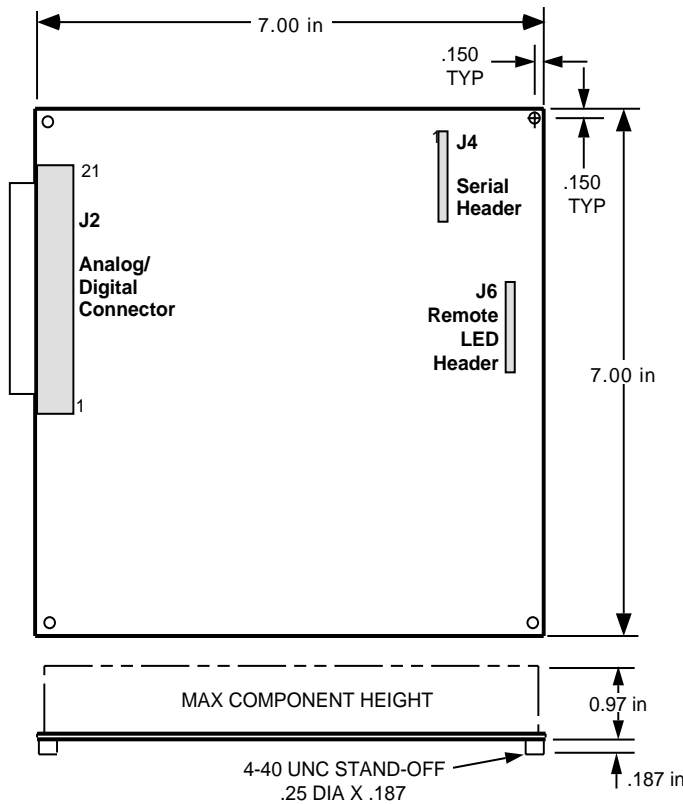

**Figure 2 2361A OEM Board Dimensions**

**TABLE 4 ANALOG-DIGITAL SIGNALS**

Signal	Pin	Signal	Pin
Vcc	1		
Digital Out V Com	2	Digital Out 3	4
Digital Out 1	6	Digital Out 4	3
Digital Out 2	5	Digital Return	28
Digital Return	7	Digital Input 3	22
Digital Ground	48	Digital Input 2	47
Digital Input 6	44	Digital Input 1	46
Digital Input 5	43	Digital Input 7	23
Digital Input 4	45	Digital Input 8	24
Analog Input 1+	11	Analog Input 1-	32
Analog Input 2+	10	Analog Input 2-	31
Analog Input 3+	9	Analog Input 3-	30
Analog Input 4+	8	Analog Input 4-	29
Analog Out 1+	42		
Analog Out 1-	21		
Analog Out 2+	40		
Analog Out 2-	19		
Analog Out 3+	36		
Analog Out 3-	15		
Analog Out 4+	34		
Analog Out 4-	13		
Chassis Gnd	12		
+ 12 Vdc Input*	17	+12 Vdc Return	16
+ 12 Vdc Input*	39	+12 Vdc Return	38
+ 12 Vdc Input*	60	+12 Vdc Return	59
Chassis Ground	53	Chassis Ground	33

# 2361A SPECIFICATIONS

## Serial Interface

Provides RS-232 full duplex and RS-485 (RS-422) half duplex asynchronous serial interfaces. Unit automatically responds to the serial interface that receives the command.

### RS-232 Interface

Signals: AB, BA and BB  
Mode: Full Duplex

### RS-485 (RS-422) Signals

Signals: TX/RX pair  
Mode: Half duplex with or without address detection  
Addresses: 0 to 15  
Termination: 220 ohm load resistor and 1 K $\Omega$  pullup/pulldown resistors.

### Common Specifications

Baud Rate: 1200 to 38.4 Kbaud  
Data bits: 7 or 8  
Stop bits: 1 or 2  
Parity: Odd, Even or None

### Command Sets

SCPI and short form commands listed in Tables 1 and 2 plus the following 488.2 Common Commands:  
\*CLS, \*ESE, \*ESE?, \*ESR?, \*IDN?, \*OPC, \*OPC?, \*PSC, \*PSC?, \*RCL, \*RST, \*SAV, \*SRE, \*SRE?, \*TRG, \*TST, and \*WAI.

### Service Request Message

SRM nn LF where nn is the Status Byte value.

### Certifications and Approvals

Meets Part 15, Class A of FCC Docket 20780 and EEC Standards EN 55022 and 50082-1.

## Analog Outputs

All parameters are specified at 25 °C. Range is jumper selected.

**Channels** 2,3 or 4  
**Ranges** 0 to +10,  $\pm 10$ ,  $\pm 5$  Vdc  
**Output current**  $\pm 5$  mA typ.  
**Isolation** 750 Vdc,  
Ch# 4 is referenced to A/D ground.

### Zero

Unipolar 0  
Bipolar Mid range  
**Resolution** 1 part in 65,535  
**Non-linearity**  $\pm 4$  bits  
**Zero error**  $\pm 8$  bits (Unipolar)  
 $\pm 4$  bits (Bipolar)  
**End Point Error**  $\pm 8$  bits

### Temp Drift

Gain  $\pm 15$  typ., 40 max. PPM/ $^{\circ}$ C  
Unipolar Offset  $\pm 25$  PPM FSR/ $^{\circ}$ C  
Bipolar Zero  $\pm 35$  PPM FSR/ $^{\circ}$ C  
**Temperature** -10  $^{\circ}$ C to +55  $^{\circ}$ C  
**Output ripple** 30 mV P-P, 500 kHz  
**Update time** 8 msec from command terminator.

## Analog Inputs

All parameters are specified at 25 °C. Polarity is jumper selected.

**Channels** 4  
**Range** 0.1, 1 or 10 volts  
**Polarity** Unipolar or bipolar  
**Max. Input** 30 V max.  
**Input Impedance** 1 Megohm  
**Isolation** 750 volts  
**Resolution** 1 part in 4096 std  
**Non-linearity**  $\pm 1$  bit on 10 V range  
**FS Error** 10V 1V 100mV  
Unipolar 5mV 1mV 0.5mV  
Bipolar 10mV 2mV 1mV  
**Temp Drift** 17 PPM/ $^{\circ}$ C  
**End Point** 2 x FS error  
**Read time** 8.5 msec max.

## Digital Lines

**Inputs** 8 lines with 33 Kohm pullups for TTL/CMOS signals or contact closure to ground.  
**Logic Levels** Low =  $0 \pm 0.5$  Vdc  
High =  $> 2.4$  Vdc  
**Query time** 10 msec to GPIB response  
**Outputs** 4 darlington driver outputs with diodes to V common input  
**Logic Levels** On < 0.7 V @ 20 mA  
On < 1.2V @ 200 mA  
Off = V Com - 0.7 V  
**V Common** 48 Vdc maximum  
**Output delay** 3 msec from comd terminator

## Physical

**Size** **W x H x D (Std Units)**  
185.2 x 38.6 x 185.2 mm  
(7.29 x 1.52 x 7.29 inches)

**Size** **W x H x D (OEM Boards)**  
177.8 x 29.5 x 177.8 mm  
(7.0 x 1.16 x 7.0 inches)

**Weight** 3 lbs (1.4 kg)

### Connectors

Analog/Digital 62-pin DC shell  
Serial 25-pin DB-25S

### Temperature

Operation -10 $^{\circ}$  C to +55 $^{\circ}$  C  
Storage -20 $^{\circ}$  C to +80 $^{\circ}$  C

**Power** +12 +1/-0.3 Vdc, 7 VA

### Included Accessories (Std Units)

Instruction Manual  
3.5 in Configuration Program Disk.  
CE/UL/CSA/VDE approved  
AC power adapters provided for:  
US - 115 $\pm 10\%$  Vac, 60 Hz (std)  
Europe - 230 $\pm 10\%$  Vac, 50/60 Hz  
UK - 230 $\pm 10\%$  Vac, 60 Hz  
Japan - 100 $\pm 10\%$  Vac, 50/60 Hz  
Mating 62-pin connector and hood

Part Number

## ORDERING INFORMATION

Serial<-> Analog Interface with A/D, 4 channels D/A, and US 115 VAC adapter	2361A-24
Serial<-> Analog Interface with A/D, 2 channels D/A, and US 115 VAC adapter	2361A-22
Serial<-> Analog Interface with 4 channels D/A and US 115 VAC adapter	2361A-14
Serial<-> Analog Interface with 2 channels D/A and US 115 VAC adapter	2361A-12
Add option code for 230 VAC adapter -E (Europe), -B (UK), -A (Australia)	2361A-nn-x

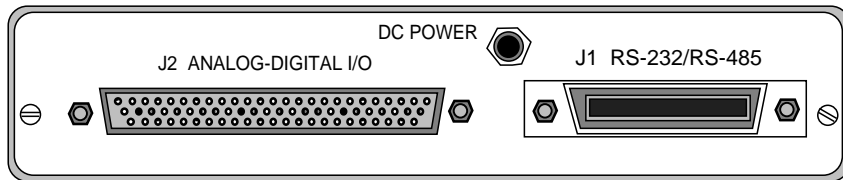

Figure 3 2361A Rear Panel