

4816

GPIB<->SERIAL INTERFACE

DESCRIPTION

The Model 4816 is a smart IEEE-488.2 compatible, GPIB <-> Serial Interface that can be used to adapt devices with RS-232 and RS-422 or RS-485 serial interfaces to the GPIB Bus. The 4816 provides an IEEE-488.2 compliant, GPIB-to-serial conversion path between the GPIB Bus and the serial device. The 4816's serial interface can be set for any standard baud rate up to 57.6 kbaud, for the common asynchronous data formats and for RS-232, RS-422 or RS-485 signals. All configuration settings are user settable and are saved in the 4816's EEPROM memory. The 4816 is designed to be mounted in a test chassis or as part of a larger system.

Typical applications are adding a GPIB interface to a sensor or instrument that has a serial interface or adding an IEEE-488.2 interface to an embedded computer board

Multiple Operating Modes

The 4816 has three operating modes to handle virtually any type of a serial device. In all modes, the 4816 passes all GPIB messages onto the serial device except that IEEE-488.2 commands and commands that start with the four reserved SCPI keywords are blocked from the serial device. The 4816 recognizes and responds to all 488.2 commands and to the reserved SCPI commands. The 4816's smart response capability gives the serial device a true, IEEE-488.2 compatible GPIB interface.

The ASYNC mode is for devices such as serial transducers that periodically output a serial message. In the ASYNC mode, the 4816 saves the last message and outputs it on the GPIB bus when next asked for serial data.

The STANDARD mode is for the majority of serial devices that receive serial messages from a controller and may return a response to the controller. In the STANDARD mode, the 4816 saves the serial response and outputs it when addressed to talk.



4816 Smart GPIB to Serial Interface

The SMART mode is for communication with microcontrollers or embedded computers that need an IEEE-488.2 interface. In the SMART mode, the 4816 passes GPIB messages to the serial device and always expects to receive a response message or an acknowledgment that the message was received. The serial device can also request to go to local mode to operate front panel controls, to query the 4816's local/remote status, to set/reset bits in the 4816's IEEE-488.2 Status Structure, and to query/set the 4816's GPIB address.

Basic Operation

The 4816 GPIB-to-Serial Interface provides a smart data path from the GPIB bus to the serial device that is transparent to most data strings and at the same time provides responses to all of the required IEEE-488.2 Common Commands and to the reserved SCPI commands and queries. It does this by checking each incoming GPIB message to see if it is an IEEE-488.2 command or a SCPI command that starts with one of the four reserved keywords: SYSTEM, STATUS, CALIBRATE and DIAGNOSTIC. If yes, the 4816 processes and responds to the messages as shown in Figure 3. If no, the 4816 places the message in the serial buffer and transmits it to the serial device. Messages containing the reserved words are not blocked if the keywords do not start the data message.

- Combines IEEE-488.2 responses and a smart GPIB-to-serial conversion path in one unit.
Adds an IEEE-488.2 compatible GPIB interface to any RS-232 or RS-422/485 serial device.
- Provides all IEEE-488.2 functions and the Status Reporting Structure.
Easiest way to add IEEE-488.2 capability to any serial device.
- Smart transparent serial data up to 57.6 Kbaud.
Does not require escape sequences or a second GPIB address.
- SCPI commands set serial configuration, GPIB address and IDN message.
Easy setup customizes the 4816 for the application.
- Operates on 5 to 15 Volts.
Works from almost any DC power source.
- Includes Diagnostic LEDs.
Provides visual indication of unit's operation, address, and selftest status.
- Support includes menu driven configuration program and GPIBkybd.
The easy way to configure the interface or use the programs as examples.



7034 Commerce Circle
Pleasanton, CA 94588
Phone: 925.416.1000
Fax: 925.416.0105
Web: www.icselect.com

4816: DEVICE MODES

Asynchronous Serial Device Operation - 4816 passes all GPIB messages onto the serial device but blocks all IEEE-488.2 commands and messages that start with the four reserved SCPI keywords from the serial device. Serial device transmits periodic serial messages. 4816 saves only the last message and outputs it in response to the `SYSTEM:COMMUnucate:SERial:RECeive:DATA?` or `RX?` queries. Asynchronous devices are transducers or other measuring devices that just output periodic serial messages.

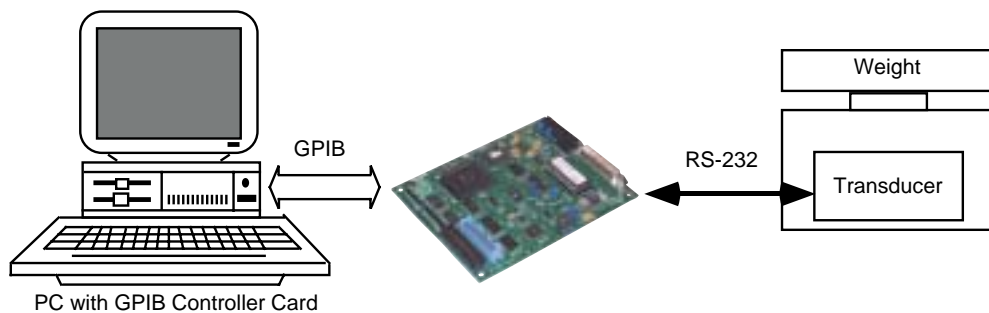

Figure 2(a) 4816 with a Transducer

Standard Serial Device Operation - 4816 passes all GPIB messages onto the serial device but blocks all IEEE-488.2 commands and messages that start with the four reserved SCPI keywords from the serial device. The serial device may output response messages when queried. The 4816 outputs the response messages when next addressed to talk. This mode handles most serial devices that need a transparent GPIB-to-Serial Interface.

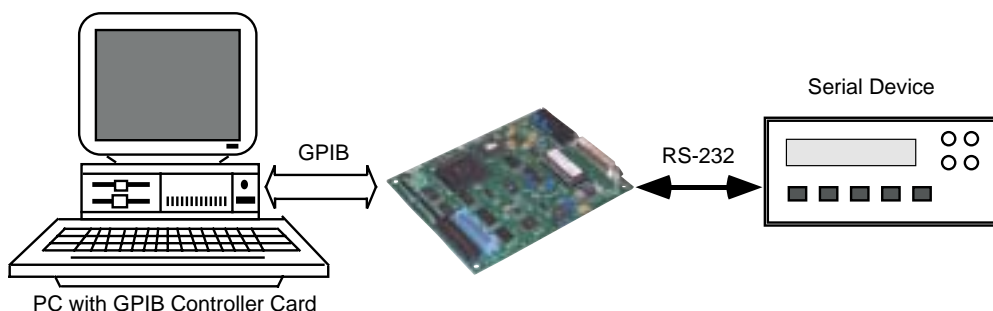

Figure 2(b) 4816 with a Standard Serial Device

Smart Serial Device Operation - 4816 passes all GPIB messages onto the serial device but blocks all messages that start with the four reserved SCPI keywords from the serial device. The 4816 responds to all IEEE-488.2 commands and sends copies of them to the serial device in case it needs to take some additional action. e.g. `*RST` may be used to reset the system. The serial device must respond to each serial message but not to the IEEE-488.2 command copies. The serial device can send responses to the GPIB bus, can pass status information by setting bits in the 4816's 488.2 Status Structure, can set/query the 4816 GPIB address and can request/query Local/Remote state. In this mode, the 4816 can also notify the serial device whenever its local/remote state changes.

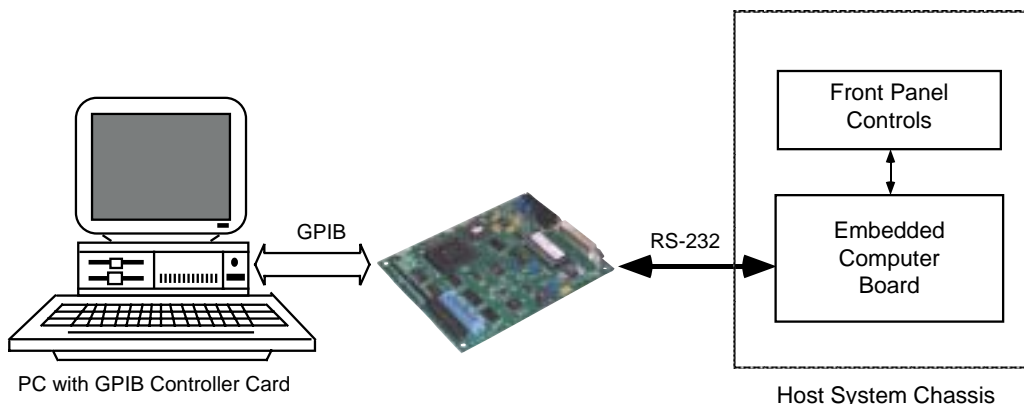

Figure 2(c) 4816 with a Smart Serial Device

4816: DESCRIPTION continued

The 4816 is configured by sending it SCPI commands over the GPIB bus. The user can set the 4816's mode, serial configuration settings and enter a custom IDN message. The settings can be saved in EEPROM memory and locked to prevent unauthorized changes. The saved settings are recalled at power turn-on as the current configuration.

GPIB Address Setting

The 4816's GPIB address is set with a SCPI command from the GPIB bus and from the serial device when the 4816 is in the Smart mode. The GPIB address takes affect immediately but must be saved if the change is to be permanent. When the Smart device changes the GPIB address, the 4816 performs an automatic save. The 4816's GPIB address setting cannot be locked so the end user can always change it.

Asynchronous Device Operation

The Asynchronous mode is for serial devices that periodically transmit messages without being queried. The 4816 saves the serial messages received from the device and outputs the last saved message on the GPIB Bus when queried for data. This converts the device's asynchronous outputs into the disciplined GPIB format.

Standard Device Operation

The Standard mode is for serial devices that receive message and may respond to queries with serial data. The 4816 passes all GPIB messages onto the serial device with the exception of all IEEE-488.2 commands and messages that start with the four reserved SCPI keywords from the serial device. Messages that contain the key words are passed to the serial device as long as the keywords do not start the message. The serial device may reply by outputting a response message when queried. The 4816 saves the response message and outputs it when next addressed to talk. This mode handles most serial devices that need a transparent GPIB-to-Serial Interface. The 4816 automatically responds to all IEEE-488.2 queries and to the reserved word SCPI commands without any serial device intervention.

When the 4816 passes a GPIB mes-

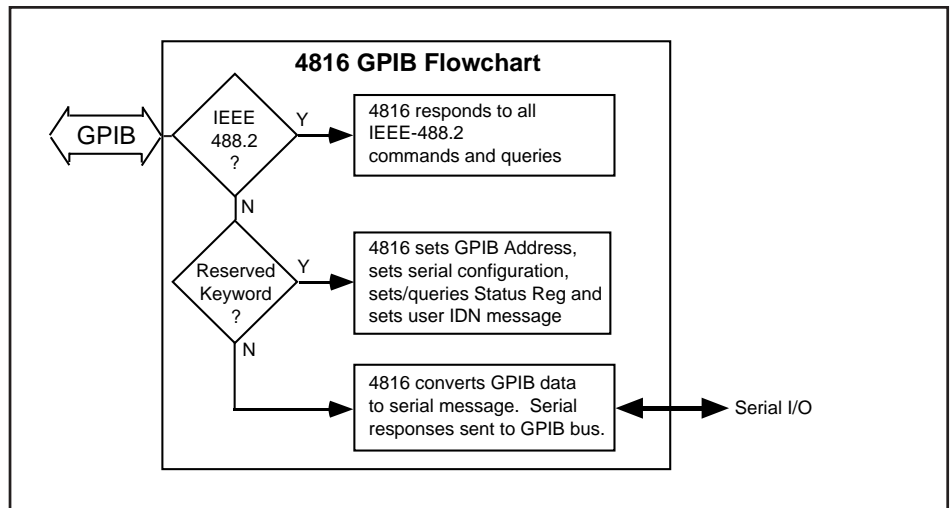

Figure 3 4816 Operation Diagram

Table 1 Smart Device Messages

Message	Meaning
@@@ESR value	Sets bits in the 4816 ESR register. Register reset when read
@@@OPER value	ORs bits into the 4816 Operational Register.
@@@OPER& value	ANDs value with the Operational Register to reset bits.
@@@QUES value	ORs bits into the 4816 Questionable Register
@@@QUES& value	ANDs value with the Operation Condition Register to reset bits.
@@@ADDR value	Sets 4816 GPIB address to new value.
@@@ADDR?	Queries current 4816 GPIB address setting.
@@@IDN string	Sets IDN response to user supplied string.
@@@SAV	Saves current configuration in flash. Same as *SAV 0 comd.
@@@REM?	Queries local/remote state. Responses are @@@REM 1 for remote, 0 for local and 3 for remote-local lockout state.
@@@LOC?	Requests 4816 to go to local state. Same replies as for @@@REM?
@@@NOREM	Disables automatic local remote change messages.
@@@LF	Tells 4816 to put a linefeed character in its GPIB buffer
@@@TO nnnn	Extends timeout by <i>nnnn</i> times to give the serial device more time to reply to this query.
@@@OK	Message acknowledgment message. Used by 4816 and Smart device if the message they just received does not have another response.
@@@ERR	4816 received an invalid message.

sage to the serial device, it starts a short timeout window and waits for the device's response. During this short time it holds the GPIB Bus from sending it an additional message. The timeout window ends when the 4816 receives a serial response or times out. A timeout indicates to the 4816 that the device has no response to the last serial message. The default timeout value is 25 milliseconds but it can be set longer by the user.

Smart Device Mode Operation

The Smart mode is intended for operation with smart devices such as embedded computers or microcontrollers. The Smart mode is similar to the Stan-

dard mode except it lets the serial device communicate with the 4816 by sending the 4816 messages that start with an "@@@" sequence. The messages listed in Table 1 let the Smart serial device pass device status information to the GPIB Controller by setting or resetting bits in the 4816's Questionable, Operation and ESR registers. Smart serial devices can also query or set the 4816's GPIB address, request that the 4816 go to the local state, lengthen the timeout period and change the IDN message. When in the Smart device mode, the 4816 can be set to send the serial device a message whenever it changes the local-remote state. The Local/remote state messages are the same as the replies to the Remote state query.

4816: DESCRIPTION continued

In the Smart device mode, the 4816 also sends copies of the IEEE-488.2 commands to the serial device in case the serial device needs to respond to the command. Examples are the *RST command which may be needed to reset the system or the *OPC command which requests that a bit in the ESR register be set when the pending operation is finished.

When in the Smart device mode, the 4816 expects a reply to all messages sent to the serial device (except for the copies of the IEEE-488.2 commands) within the preset timeout period. If the serial device does not respond to the GPIB Bus Controller, it replies with the @@@OK acknowledgment. The 4816 also replies to all messages that it receives from the serial device. This keeps the two devices in sync. If a message does not have a valid response, then the @@@OK acknowledgment is used as the response.

4816 Status Reporting Structure

Figure 4 shows the 4816's IEEE-488.2 Status Reporting Structure. In all modes, the 4816 sets and resets the ESR, Operational Register and Status Register bits based upon conditions that it detects. The user can enable SRQ generation by setting the corresponding bits in the ESE, Operational Enable and SRE registers so that a true condition will generate a Service Request and assert the SRQ line. The Operational Register also has a Transition Register which can select positive or negative bit transitions to set the Event Register. Querying the ESR or an Event register resets its bits. The bits in the Operational Condition Register are reset when the condition changes. For more information about the IEEE-488.2 Status Structure, refer to ICS's Application Bulletin AB48-11.

In the Smart mode, the designer can use unassigned bits in the Questionable and Operational Registers to report product status conditions. The Smart serial device can then set and reset these bits as the product status changes. The end user can enable the bits to generate an SRQ or he can periodically query either register. The Smart serial device can also set bits in the ESR register to indicate a command error or to indicate that the commanded action has been completed. The 4816 automatically sets

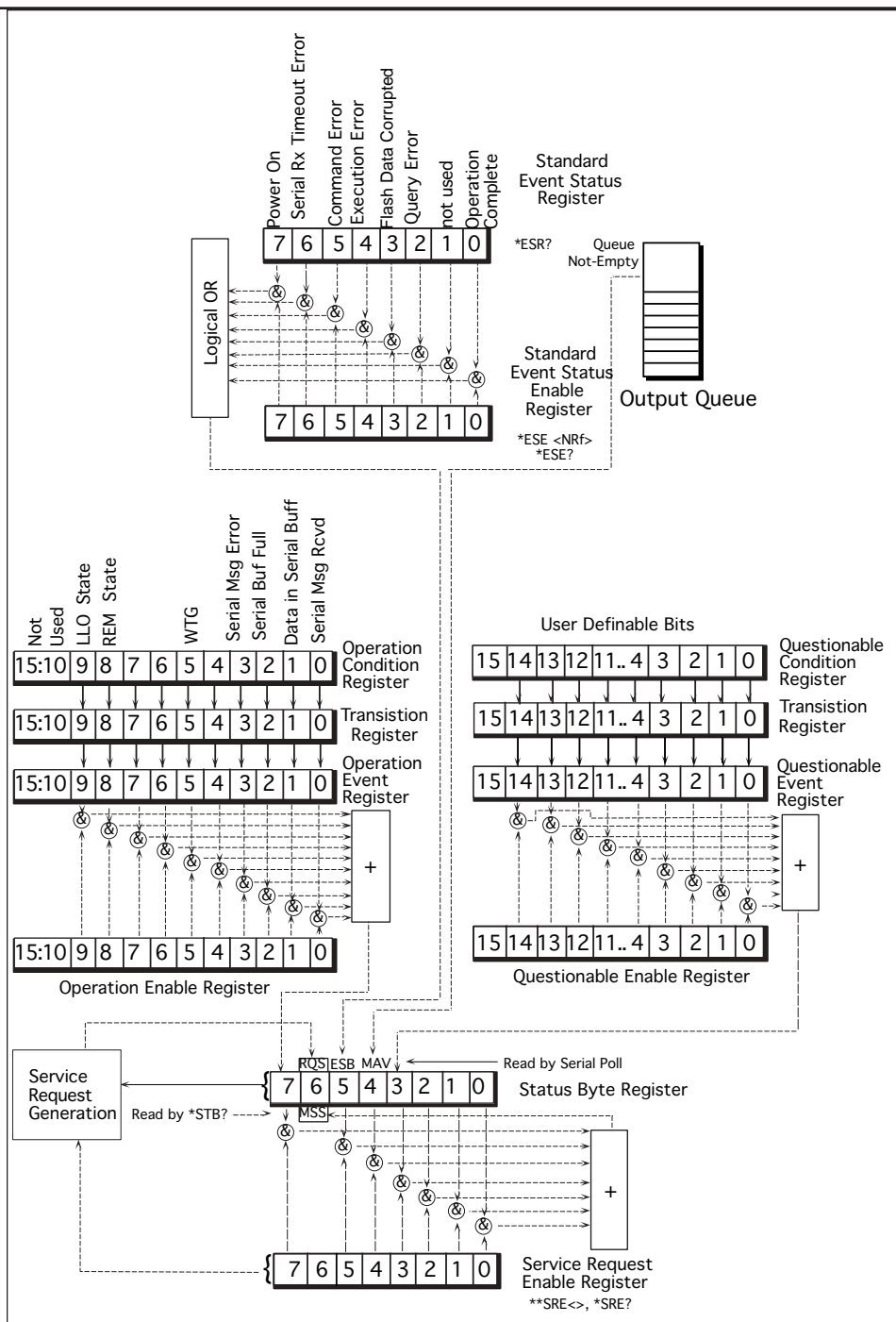

Figure 4 4816 IEEE-488.2 Status Reporting Structure.

the MAV bit whenever there is data in the GPIB buffer.

4816 Connections

The 4816 uses one of two GPIB headers. J2 is the 26-pin header by the edge of the board, includes address switch inputs and mates with ICS's GPIB Connector/Address Switch Assemblies. These assemblies mount a GPIB Connector and an Address Switch on the rear panel. J1 is a 24-pin header with just GPIB signals and mates with a GPIB flat-ribbon cable. The cable provides a

GPIB connector and metric studs that mounts on the rear panel.

The 4816 has two Serial connectors with the same RS-232 and RS-422 signals. The 25-pin DB connector, J4, mates with a DB-25S connector and is easier to use with standard wires while the 24-pin header, J3, mates with flat-ribbon cables. Jumpers select RS-232 or RS-422/RS-485 signals.

The 4816 includes a low voltage drop-out regulator for operating from unregulated 5.5 to 15 volt DC power. A jumper bypasses the regulator for operation from regulated 5 Vdc power.

4816: SPECIFICATIONS

IEEE 488 Bus Interface

The 4816's 488 Bus Interface meets IEEE STD 488.1-1987 and has the following capabilities as a GPIB-to-Serial converter:

- SH1, AH1, T5, L3, SR1, PP1, DC1
- RL0, DT0, C0 and E1/E2 drivers

Bus drivers incorporate power up/down protection to prevent glitching the bus during power turn-on.

Address Capability

Primary addresses 0-30 set by GPIB bus command. Address displayed on LED indicators at power turn-on.

SRQ Generation

SRQs are generated per the IEEE-488.2 specification when the unit is not addressed to talk and an enabled bit in the ESR, Questionable or Conditional register becomes set.

Parallel Poll Response

Reports SRV Status in PPR bit

Buffers and message lengths

GPIB Input 256 bytes
Serial Input 256 bytes

488.2 Common Commands

*CLS, *ESE, *ESE?, *ESR?, *IDN?, *OPC, *OPC?, *RST, *SAV, *SRE, *SRE?, *STB, *TST?, AND *WAI.

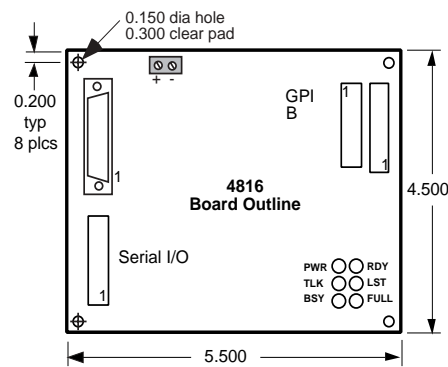

4816 Outline Dimensions

Serial Interface

Provides RS-232C single ended or RS-485 (RS-422) differential signals on a DB-25S connector and header. Pin assignments conform to EIA RS-530 specification and are pin compatible with most RS-232 devices. Signal selection by internal jumpers.

Baud Rates 50 to 57.600 baud std, Closest integer rate for nonstandard rates.

Data Character Formats

Data bits 7 or 8 bits
Parity Odd, even or none
Stop bits 1 or 2

Modes

Full-duplex - transmitter always active.
Half-duplex - transmitter tristated 0.2 ms after last character.

Data Transfer Protocols

Hardware handshake always enabled.
X-on /X-off handshake enabled or disabled by a separate command.

Table 2 RS-232C Signals

Pin	# Signal
1	Chassis
2	Transmit Data
3	Received Data
4	Request-to-Send
5	Clear-to-Send
7	Ground
8	Signal Detected
20	Data Terminal Rdy

Table 3 RS-424/RS-485 Signals

Pin	# Signal
1	Shield
2/14	Send Data
3/16	Received Data
4/19	Request-to-Send
5/13	Clear-to-Send
8/10	Signal Detected
20/2	Data Terminal Rdy

Indicators

Six on board LEDs show selftest diagnostics, GPIB address and status.

- PWR On when power applied
- RDY On when Selftest passed
- MTA On when talk address recognized
- MLA On when listen address recognized
- SRQ On when SRQ generated
- ERR On when ESR error bit set

Physical

Size L x W x H

139.7 x 114.3 x 12.7 mm
(5.5 x 4.5 x 0.5 inches)

Weight

6 oz. (0.17kg.)

Connectors

GPIB: 24-pin 3M 2524 male conn.
GPIB/Addr: 26-pin 3M 2526 male conn.
Serial: 26-pin 3M 2526 male conn. and DB-25P male conn.

Temperature

Operation -10 °C to +70 °C
Storage -20 °C to +85 °C

Humidity

0-90% RH without condensation

Shock/Vibration

Normal handling only

Construction

PC Board

Power

9 to 15 Vdc @ 300 mA

Included Accessories

Instruction Manual
Support CD-ROM

SCPI Commands

The 4816 conforms to the SCPI 1994.0 Specification and uses SCPI commands to set its configuration: The reserved SCPI Keywords are:

- SYSTEM
- STATUS
- CALibrate
- DIAGnostic

ORDERING INFORMATION

4816 GPIB - Serial Interface Module (includes Manual and Support CD-ROM)

4816

4816 Board only, no Manual or Support CD-ROM

115422

Horizontal GPIB Connector-Switch Assembly with flat ribbon connector for J2. L= length in cm., 90 cm max.

113640-L

Vertical GPIB Connector-Switch Assembly with flat ribbon connector for J2. L= length in cm., 90 cm max

113642-L

GPIB Flat Ribbon Cable Assembly with flat ribbon connector for J1. L= length in cm., 90 cm max.

114439-L