

IEEE 488 BUS EXPANDER/ISOLATOR

4860A ISOLATED BUS EXPANDER

DESCRIPTION

ICS's 4860A GPIB Isolated Bus Expander solves four of the most common problems encountered in GPIB systems - device loading, signal noise, ground loops and cable distance. ICS's 4860A Expander complies with the IEEE-488.2 Standard and does not give false responses when GPIB Controllers or application execute the FindListener protocol, even when devices on the isolated bus are turned off. Use the 4860A for device isolation, bus expansion, to prevent ground loops and for noise reduction.

Bus Expansion

The 4860A Isolated Bus Expander allows a user to connect up to 27 GPIB devices to a single controller and overcome the specification limit of 14 devices and 20 meters of bus cables in an IEEE 488 Bus system. To increase the number of units in a system beyond 14 devices, one of the existing devices is replaced with a Model 4860A which then drives up to 14 additional devices as shown in the figure below. The 4860A Isolated Bus Expander also drives an additional 20 meters of cable which extends the maximum cable length to 40 meters. Multiple Bus Expanders can be used in parallel to add even more devices to the system or extend the cable length.

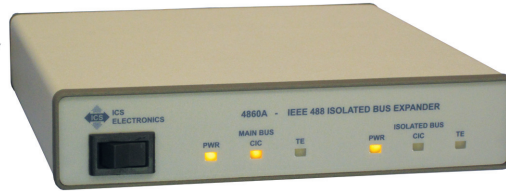

4860A Isolated Bus Expander

Electrical Isolation

The Model 4860A provides over 2000 volts of electrical isolation and increased common mode noise rejection between a group of instruments and the IEEE 488 Bus controller. This eliminates measurement problems caused by ground loops and reduces common-mode noise errors in both analog and digital systems.

No Programming Changes

The 4860A is invisible to the bus controller and does not require any special programming. The user can freely use the FindLstn and other 488.2 protocols in his program. The System Controller is connected to the 4860A's local Bus connector. The Controller-in-charge can be on either side of the Bus Expander. Controller location is automatically determined by logic in the 4860A.

- Provides over 2000 volta isolation between instruments and bus controller.
Eliminates ground loops, noise and associated data errors.

- Allows more than 14 devices on the GPIB bus.
Overcomes the bus drive limitation.

- Extends the bus length an additional 20 meters.
Overcomes the bus length limitation.

- No false responses to the FindLstn Protocol
Supports all IEEE 488.2 protocols.

- Invisible to the IEEE 488 Bus controller.
Needs no bus address or special programming.

- Fast handshake rate.
Doesn't slow your system.

- Front panel indicators show controller and talker locations.
Visual operating status.

- Metal case provides EMI/RFI protection
Proven EMI/RFI Compliance.

CE Approved

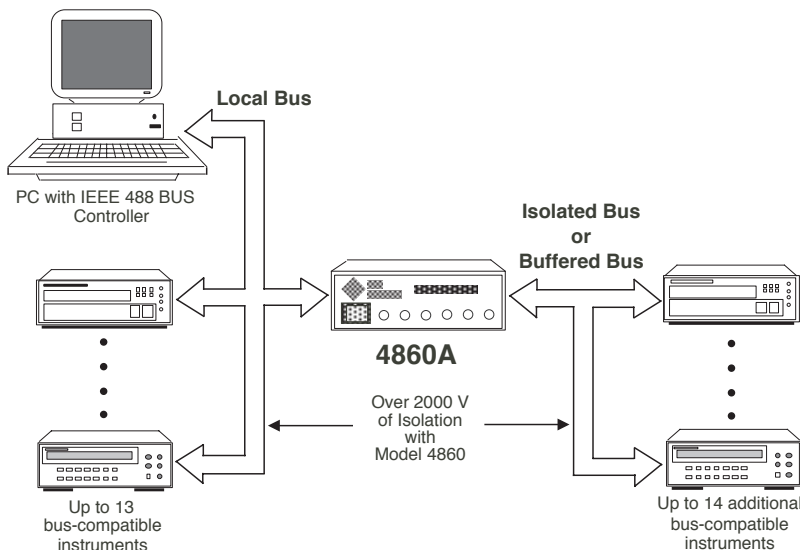

Figure 1 Bus Expander adds up to 13 additional devices to a GPIB Bus System



7034 Commerce Circle
Pleasanton, CA 94588
Phone: 925.416.1000
Fax: 925.416.0105
Web: www.icselect.com

4860A SPECIFICATIONS

IEEE 488 Buses

Two bus connectors, one for Local Bus and one for Isolated Bus. Shell and shield lines of isolated connector are floating.

IEEE 488.1 Compliance

All 16 lines on both bus connectors meet the electrical specifications of the IEEE Std 488.1-1987.

I_{in} (low state) is 0.25 mA at 0.4 Vdc

I_{in} (high state) is 40 mA at 0.4 Vdc

V_{out} (low state) is 0.5 Vdc at 48 mA

V_{out} (high state) is 2.6 Vdc minimum

Signal Pass-Through

Signal	Direction
IFC, REN	From local bus
All others	Bidirectional

Controller Location

System Controller - Main Bus

Controller-in-Charge - Either Bus

Configurable Settings

Local Bus E1/E2 Drivers

Isolated Bus E1/E2 Drivers

IEEE 488.2 Compliance

No false responses to FindLstn Protocol. Works with all 488.2 Protocols.

No false responses if all of the devices on the isolated bus are powered off.

Front Panel Indicators

Three Local Bus indicators:

PWR	Indicates power on
DC	CIC on Local Bus
TE	Data direction to Local Bus

Three Isolated Bus Indicators:

PWR	Indicates isolated power on
DC	CIC on Isolated Bus
TE	Data direction to Isolated Bus

Transfer Timing-Signal Propagation

All - 80 ns typical, 180 ns maximum

Handshake Delay

600 ns typical (supports transfer rates > 670 Kbytes/sec.)

ATN Response

NRFD and NDAC asserted 600 ns after ATN to compensate for remote device delay.

Approvals/Certificates

EMI/RFI

Meets Class A Part 15 of FCC Docket 20780 and EN55022 and EN 50082-2 specifications. CE approved.

UL/CSA

Power Adapter meets UL 1950/IEC 950 and has UL/CUL/FCC/LPS/PSE/BSMI/RCM/TUV/CE/WEEE/ROHS/V approval.

Physical

Size W x H x D

7.29 x 1.52 x 7.45 inches
(185.2 x 38.6 x 189.2 mm)

Weight 3

3 lbs (1.4 kg)

Temperature

-10°C to +55°C Operating

-40°C to +70°C Storage

Humidity

0-90% RH no condensation

Construction

All metal case

Connectors:

IEEE-488 Buses: 24-pin connectors with metric lock studs

Power

9 to 32 Vdc @ 5.5 VA nominal

100-230VAC with supplied Power Adapter.

Bus Isolation

> 2000 Vdc bus-to-bus or to chassis ground

Included Accessories

Instruction Manual

UL/CSA/CE approved, energy efficient,, 100/230 VAC, 50/60 Hz. Power Adapter with US/Japan, Europe, UK and Australia/China plugs

ORDERING INFORMATION

IEEE 488 Bus Expander/Isolator with 115/230 VAC adapter

See separate data sheet for IEEE Bus Cables and Minibox Rack Mounting Kits

Part Number

4860A