

# LAN GPIB GATEWAY

# 8065

## Ethernet-to-GPIB Gateway

### DESCRIPTION

ICS's 8065 is a Ethernet-to-GPIB Gateway that lets you control your GPIB instruments over an in-house network or over the Internet. The 8065 makes it easy to run instruments at your workbench, to share test equipment with others or to run remote tests anywhere in the world over the internet. The 8065 connects to any TCP/IP network or to a network port on your computer.

The 8065 is a VXI-11 compliant network service which can be easily controlled by several programming techniques. Windows users can control the 8065 through VISA layers from Agilent, National Instruments, and other vendors. ICS's VXI-11 Keyboard utility for Windows lets you find and control GPIB instruments connected to the 8065. Unix, Linux and other operating system users can control the 8065 with RPC (Remote Procedure Call) calls over a TCP/IP network. RPC provides an invisible communication medium allowing the developer to concentrate on his program and eliminates driver problems caused by kernel or OS variations.

### VXI-11 and VISA

The Model 8065 is a VXI-11 compliant Server and the test program is the client. VXI-11 is a communication standard developed in conjunction with the VISA Specification. VISA layers provide programmers with a vendor independent API that can be called by their programs. Popular graphical test programs like LabVIEW and VEE as well as C language and Visual Basic programs can make VISA calls so they can be used with different vendors' GPIB Controllers. With VISA, instruments and controllers are considered as VISA resources. The same VISA program that ran a PCI or USB GPIB Controller can run the 8065 by changing the resource designation. When the user designates a TCP/IP resource like ICS's 8065, it is accessed through the VISA layer's VXI-11 interface.



8065 Ethernet-to-GPIB Controller

### Programming

If you program with Agilent VEE or other Agilent programs, you can use Agilent's VISA or its internal SICL library to control ICS's 8065. The Model 8065 is fully VXI-11 compliant and is interchangeable with Agilent's E5810A and older E2050B if you are not using their RS-232 interfaces.

If you program with LabVIEW, National Instruments' VISA supports the 8065 with VXI-11.3 calls. NI's Measurement and Automation Explorer treats the 8065 as any other TCP/IP resource.

If you use a WIN32 operating system and are a Visual Basic or C/C++/C# programmer, you can write your program with RPC, SICL or VISA calls to control your GPIB instruments.

If you use Linux or any variation of Unix like SunOS, IBM-AIX, HP-UX, or Apple's OS X, you can communicate with the 8065's RPC Service either through RPC over TCP/IP or with VISA calls.

If you program with Java then you can write a 8065 control program that can be easily moved to virtually any operating system. The Java jG-pibEnet project on SourceForge was developed using an ICS 8065 Controller.

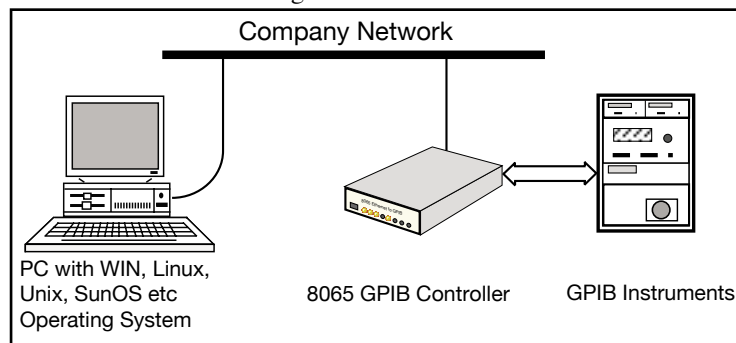

Figure 1 8065 shown connected to Company Network

- Remote control of GPIB instruments via the Internet or in-house network. *Control GPIB and HP-IB Devices anywhere there is a network connection.*
- Runs from any VXI-11 compliant VISA library. *Use VEE, LabVIEW, C, and Visual Basic programs with VISA or SICL calls.*
- Easily controlled by RPC calls over TCP/IP. *Adds GPIB Controller capability to Unix, Linux, SunOS and similar operating systems.*
- Does not require special drivers for each operating system. *Eliminates driver problems.*
- Includes ICS's VXI-11 Keyboard Controller program for interactive control of GPIB devices. *Lets you control instruments without writing a program.*
- Handles multiple clients. *Shares equipment among multiple users.*
- Internal WebServer with network setup pages. *Change network settings with any web browser.*

 RoHS Compliant

 Approved



 **ICS ELECTRONICS**  
division of Systems West Inc.

7034 Commerce Circle  
Pleasanton, CA 94588

Phone: 925.416.1000

Fax: 925.416.0105

Web: [www.icselect.com](http://www.icselect.com)

### No Special Drivers required

You do not need special drivers when you communicate with the 8065 by using RPC calls from Linux or any Unix like system. These systems include an `rpcgen` utility that can convert the VXI-11 Specification's RPCL header file into a operating system library file that can be called with your C language program. Therefore there is nothing to become obsolete or need changes, nor is a new driver required when the test computer or the operating system is updated or when the test program is ported to another system.

### Keyboard Controller Program

The 8065 includes ICS's VXI-11 Keyboard program for Windows which provides interactive control of GPIB devices from the computer keyboard without having to write a program. The VXI-11 Keyboard program is the ideal utility program for testing the 8065 Controller, for exercising GPIB devices or for trying out device commands before using them in a program.

With the VXI-11 Keyboard program you can find and link to your 8065s, read back Bus Status, generate IFCs, run the 488.2 FindLstn protocol to discover the GPIB devices connected to the 8065, and link to an instrument. Besides reading and writing data strings, the VXI-11 Keyboard has controls for Device Clear, Device Trigger, and Serial Poll. Instrument links can be locked manually or automatically to prevent another user from interfering with your use of the GPIB devices.

### Ease of Installation

ICS's 8065 is very easy to install. Plug the 8065 into a network access point adjacent to your computer as shown in Figure 3 or use an Ethernet crossover cable to connect the 8065 directly to a PC's network port as shown in Figure 4. Then use your favorite web browser or run ICS's Configuration Utility to configure the unit for your network. Both let you set the 8065 to a static IP address or you can enable the 8065 to accept an DHCP address setting if your network has a server that can assign network addresses. Then set the remaining network and GPIB bus parameters. Save the setup and the 8065 is ready to be connected to your network.

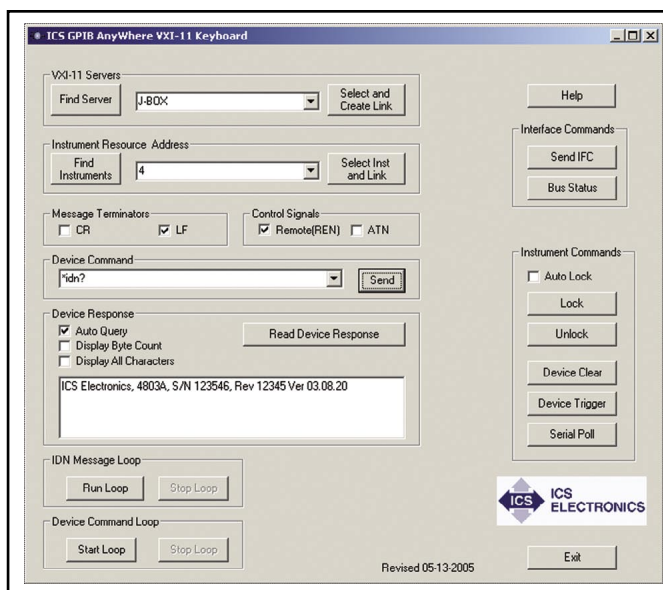

Figure 2 VXI-11 KeyBoard Controller Panel

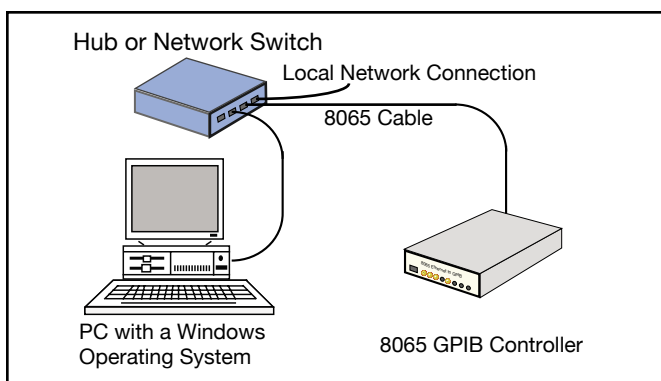

Figure 3 8065 Configuration Connections

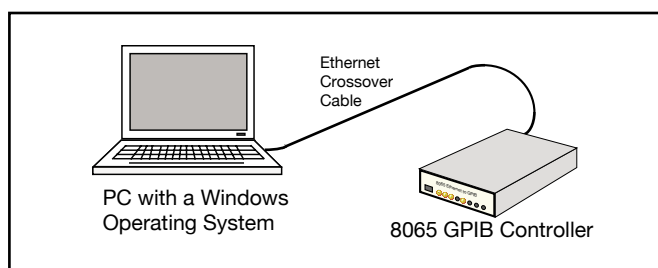

Figure 4 8065-Laptop Connection

The 8065 has a rear panel LAN Reset button that can be used to reset the 8065's network settings to the factory default settings in case the 8065's configuration needs to be reset or if the settings were lost.

### Easy Firmware Updates

The 8065 has a program download and store function which lets the 8065 receive program changes through its Ethernet interface. If a future firmware change is necessary, the new firmware and Upgrade Utility program can be downloaded from ICS's website. The 8065 validates the new code before saving it

in its Flash memory. The original factory code is never overwritten so the user can always revert back to the factory code.

### Hardware

ICS's 8065 Controller is packaged in ICS's small metal Minibox™ case that provides proven EMI/RFI protection and rack mount capability. Rear panel RJ-45 and GPIB connectors provide access to the network and to the GPIB bus. Front panel LEDs provide visual indication of the network and GPIB bus status and diagnostic help for troubleshooting system problems.

One or two 8065s can be rack mounted in a 1 U high space. Chose from a single rack kit that holds one unit or the dual rack kit that holds two units.

### Network Communication

The client application uses the VXI-11 or RPC protocol to communicate with the 8065 and to control and transfer data to and from GPIB instruments. Both protocols operate over a TCP/IP network. The TCP transportation layer and IP protocol guarantees error free communication with the 8065 over the network or Internet as long as the connection is maintained.

The 8065 has communication timeout and keepalive capability to maintain the communication link with the client application. When the 8065 discovers that the channel is no longer active, or when a channel is closed, it closes that channel and releases all

resources that were used by the client. This unlocks any instruments links, destroys the links and returns all resources to the pool for the next user.

An auto-disconnect feature is included in the 8065 for compatibility with programs designed for the Agilent (HP) LAN to GPIB Controllers. If the user enables auto-disconnect, the channel is aborted automatically whenever the link count goes to zero. This feature should only be used for compatibility with existing programs as channels should only be closed by the client and not the server.

## Multiuser Capabilities

ICS's 8065 Ethernet to GPIB Controller supports up to 15 clients at a time. This lets multiple users share equipment from anywhere in the world at anytime.

Figure 5 on the right shows a 8065 being used to control a rack of test instruments on a factory test floor. The test technician's computer and the 8065 are both connected to a local network hub or switch. The test program is normally run in the test technician's computer.

When the Test Engineer has to upgrade or modify the test program he can run the new program from his computer and make any necessary changes without having to have a duplicate set of the production test equipment in his lab. This is a significant cost savings.

The Field Engineer can use the company's Virtual Private Network (VPN) to gain access to the company's network over the Internet. He too can become a 8065 client with out impacting the test setup. In companies with multiple test locations, VPN connections can allow the Test Engineer to access and update test programs anywhere in the world from his home office.

In a production test environment, the Engineering and Field Engineer would normally not access the Test Equipment at the same time that it was being used by the Test Technician. However, in other applications with remote data collection equipment, such as in a weather station, the instruments could be accessed by several clients at the same time. Here one client may be looking at a data logger while another client could be reading current conditions. The 8065 supports multiple clients using different instruments at the same time.

## VXI-11 Background

The VXI-11 Standard was created as a way to control instruments over a TCP/IP network. VXI-11 is the overall VXI-11 document and describes the RPC protocol. The VXI-11 Specification includes the necessary RPCL header files to generate the RPC calls. RPC calls can be used with virtually any operating system that has TCP/IP communication capability. Copies of the VXI-11 Standard are available at <http://www.vxibus.org>.

VXI-11 has three sub-standards: VXI-11.1 is for a VXI chassis and is not applicable to the 8065. The VXI-11.2 describes the operation of a GPIB Controller such as ICS's

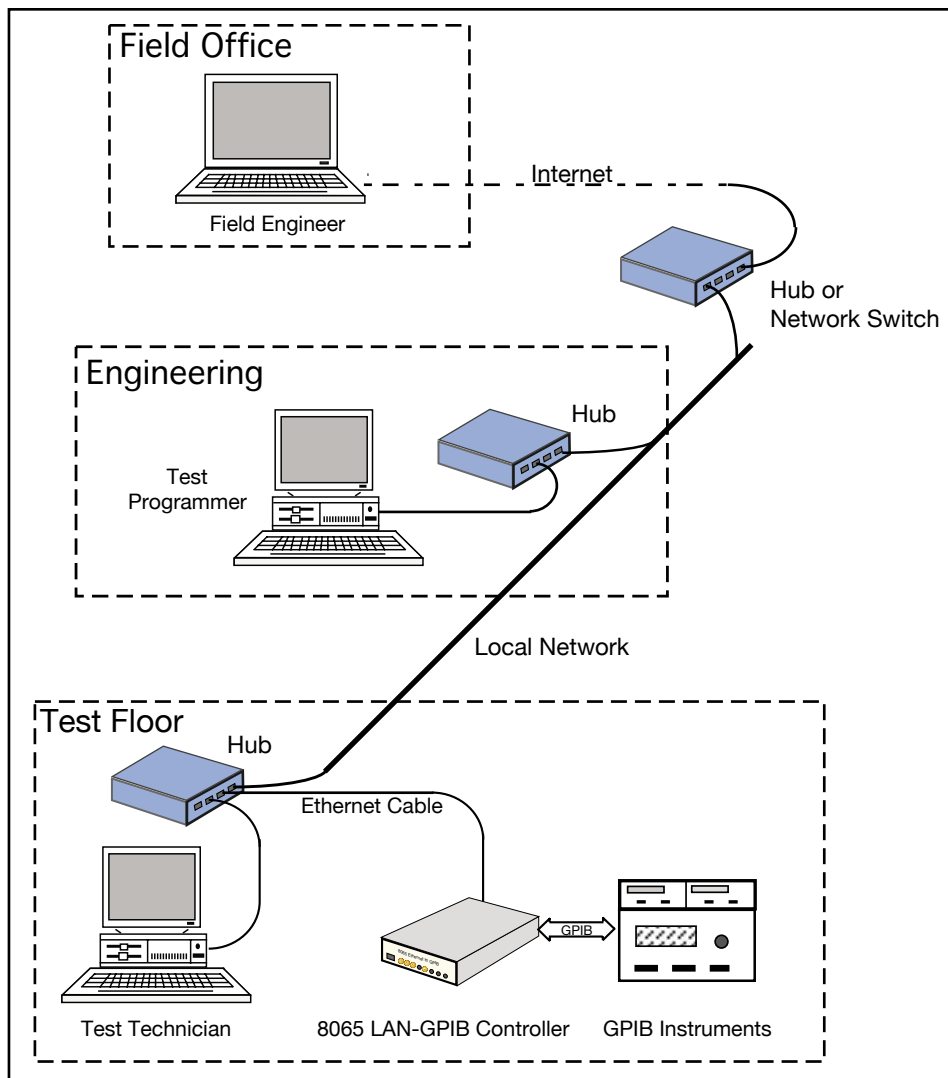

Figure 5 8065 Multi-user Application

Model 8065. VXI-11.3 describes the control of LAN instruments.

The 8065 responds to all VXI-11.2 commands to control the GPIB interface. These commands let the 8065 operate as an IEEE-488.1 Controller and do such familiar tasks as transfer data to/from devices, send Device Clear and Device Triggers, pulse the IFC line, set/reset REN, set/reset ATN, perform Serial Polls and read back the states of the REN, NDAC and SRQ lines. The 8065 also sends 488.1 commands and addresses to the device.

The 8065 responds to all VXI-11.3 commands to pass device commands and IEEE-488.2 Common Commands onto the selected device and to return all responses to the client application. FindLstn and the other 488.2 Controller Protocols can be implemented in the client application and utilize the 8065's IEEE-488.1 controller capabilities to perform the required functions.

## 8065 Advantages

ICS's 8065 is a newer product and takes advantage of today's newer technologies. The 8065 is a 100 percent VXI-11.2 and VXI-11.3 compatible Ethernet-to-GPIB Controller. What this means to you is complete GPIB control capability and the ability to implement the IEEE-488.2 Controller Protocols like FindLstn. Some competitive units only have VXI-11.3 capability.

The 8065 supports SRQ handling, serial polling and SRQ notify. The 8065 also supports multiple clients as part of its standard firmware making it easy to share equipment from remote locations.

The 8065 is more universal since its use is not limited by the availability of a driver for a specific operating system. Moreover, the resulting test programs are more robust since they are free of any driver bugs. Finally the 8065 is designed as a RoHS compliant instrument and meets every country's environmental specifications.

# 8065 SPECIFICATIONS

## Supported Standards

### IEEE 488.1 Capabilities:

The 8065 meets IEEE-STD-488.1 with the following capabilities:

- AH1, SH1, C1, C2, C3, C4, and C9
- E2 Drivers incorporate power up/down protection and drive 14 devices.

### IEEE 488.2 Compatible

Runs all required 488.2 controller protocols and includes bus signal line monitoring.

### 488 Bus Performance

Long term GPIB transfer rates are limited by the LAN data transfer rate, the Client-computer performance and the GPIB device. Short term 8065 data rates are:

- GPIB to 8065 > 125 kbyte/s
- 8065 to GPIB > 180 kbytes/s

- GPIB Drivers 14 loads or devices
- Device Address 64 addresses-any combination of primary or primary and secondary addresses.
- 8065 address 0 to 30 [0]

### VXI-11 Capabilities

Fully VXI-11.2 and VXI-11.3 compliant

- VXI-11.2 Interface Control
- VXI-11.3 Device Control
- Clients 1 to 15
- Channel types Data, Abort and Interrupt
- Instrument links 64 max

### RPC Protocol

Conforms to ONC RPC Version 2

### Ethernet Interface

- Type IEEE 802.3 compliant
- Speeds 10BaseT (10 Mb/s)  
100BaseT(100 Mb/s)
- IP Address Static or DHCP
- Factory setting 192.168.0.254 static
- Interface name any [gpib0]

### Internal WebServer

The internal WebServer provides HTML web pages for viewing and setting the 8065's network and GPIB bus settings.

## System Requirements

Computer with an IEEE 802.3 LAN interface. Requires RPC support or a VXI-11 compliant VISA layer installed.

## Supported Software

The 8065 supports the following application and program languages:

- NI LabVIEW (5.1 thru 8.6)
- Agilent VEE - IO Libraries 14.2 and later
- MathWorks MathLab
- Visual Basic 6.0\*
- Visual Basic .NET (2005)\*
- Visual C, C++ and C#\*
- Java\*

\* with VISA or RPC calls

## Controls and Indicators

### CONTROLS

- Power Front-panel switch
- LAN Reset Rear-panel push-button

### LEDs

- PWR Power on
- RDY Unit has passed self test
- LNK Unit connected to an active LAN
- ACT Transferring messages to/from the network
- TALK Unit is addressed to talk
- LSTN Unit is addressed to listen
- SRQ SRQ asserted on GPIB bus
- ERR Unit has detected a soft error

## Physical

Size 7.45" L x 5.57" W x 1.52" H  
(18.92 cm L x 14.15 cm W x 3.86 cm H)

Weight 1.6 lbs. (0.73 kg.)  
plus power adapter

Construction RoHS Compliant

Temperature  
Operating -10 °C to +65 °C  
Storage -40 °C to +70 °C

Humidity 0-90% RH non-condensing

Shock/Vibration Normal handling

Connectors  
GPIB GPIB 24 pin ribbon with metric studs.  
Ethernet RJ-45

Power 9 to 32 Vdc @ 4 VA

RFI/EMI CE Certified

EEC Standards EN 61000-6-4:2001,  
EN 61000-6-2:2001,  
EN 55024:1998,  
and EN 55022:1998.

## Included Accessories

Instruction Manual

CD-ROM with VXI-11 Keyboard Controller program and Configuration Utility.

LAN Crossover Cable.

UL/CSA/VDE approved AC power Adapters provided for:

- US - 115±10% Vac, 60 Hz (std.)
- E Europe - 230±10% Vac, 50/60 Hz
- B UK - 230±10% Vac, 60 Hz
- U Japan - 100±10% Vac, 50/60 Hz
- A Australia - 230±10% Vac, 60 Hz
- China - 230±10% Vac, 60 Hz

## NOTE

For more information and programming examples refer to the AB80 series Applications Notes at [www.icselect.com](http://www.icselect.com)

LabView is a trademark of National Instruments, Austin, TX.

VEE, IntuiLink and Benchlink are trademarks of Agilent Technologies, Palo Alto, CA.

The VXI-11 Specification is available from the VXI Consortium at <http://www.vxibus.org/specs.html> or from ICS's website at [http://www.icselect.com/vxi\\_spec.html](http://www.icselect.com/vxi_spec.html)

## ORDERING INFORMATION

Part Number

Ethernet - GPIB Controller with 115 VAC adapter, Manual and CD-ROM 8065

Ethernet - GPIB Controller with 230 VAC adapter, Manual and CD-ROM (Specify plug style) -E (Europe), -B (UK), -A (Australia)

GPIB Accessory Cables See separate data sheet

Rack Mounting Kits (holds one or two 8065s). See separate data sheet Single - 114210, Dual - 114211